

S E R I E S T E C H N O L O G I E S N r 1 1



Compressed earth blocks

standards



Centre for
the Development of Industry
ACP - EU



CRATerre-EAG
BASIN

Compressed earth blocks

standards

The Centre for the Development of Industry (CDI), over its twenty years of operation, has built up a significant body of technical and commercial knowledge at the service of launching, developing and rehabilitating small and medium-sized enterprises in ACP countries (Africa, Caribbean, Pacific). It has done so particularly thanks to setting up sustainable partnerships with European Union enterprises.

In publishing its "Practical Guides" series, the CDI is responding to a need clearly expressed by ACP promoters and by EU entrepreneurs wishing to set up an industrial collaboration with these countries. These guides aim to enable them to adapt to the technical, commercial, financial, administrative and legal environment proper to different local contexts. Intended to make their task easier in a concrete manner - in simple and practical terms - in a field or in precise areas of their activities, they aim above all to be an efficient tool at the service of the manager.

In preparing these documents, the CDI turns to consultants, researchers and practitioners - both from ACP countries and from the European Union - who have a wide experience of the subject in question, and of the practical problems entrepreneurs actually encounter and of the solutions to be applied. When circumstances allow, the CDI works jointly with a co-editor (a consultancy group, research organisation, specialised institution etc.) in order to ensure that the guides are distributed as widely as possible.

This document has been prepared in collaboration with CRATerre-EAG (the International Centre for Earth Construction - School of Architecture of Grenoble), with the support of ARSO (African Regional Organization for Standardization) and the geomaterials laboratory - URA of CNRS n° 1652 of the ENTPE (National Engineering Institute for Public Works of Lyon). This document is an output from a project co-funded by the UK Overseas Development Administration (ODA) for the benefit of developing countries. The views expressed are not necessarily those of the ODA. The information contained in this guide is provided in good faith by the CDI, CRATerre, ARSO, experts and consultants. They cannot, however, be held responsible for any errors, inaccuracies, deficiencies or possible omissions or for their consequences.

Co-ordination: Boubekeur S. (CDI), Houben H. (CRATerre-EAG)

Editorial committee: Doat P., d'Ornano S., Douline A., Garnier Ph., Guillaud H., Joffroy Th., Rigassi V.

English translation: Norton C.

Publication and rights : This volume of CDI guides is a joint CDI and CRATerre-EAG publication.
© 1998 CDI and CRATerre-EAG/ODA.
Reproduction authorised subject to the source being acknowledged, except for commercial purposes.
ISBN 2-906901-19-9

Diffusion : Not for sale by persons or distributors other than those agreed CDI and the co-publisher. Price 20 Ecu's.

CDI
Center for the Development of Industry
(Lomé ACP-EU convention)
52 avenue Herrmann Debroux
B-1160 Brussels - Belgium
Telephone +32 2 679 18 11
Telecopie +32 2 675 26 03
Telex 61427 cdi b

Preface

It emerged clearly from the sector survey of building and public works construction materials in Central Africa presented at the MAT-CONSTRUCT'95 industrial forum held at Libreville, Gabon by the EU, UDEAC and the CDI in October 1995, that earth building technology, and more specifically that of compressed earth blocks, forms an integral part of the building industry.

The materials manufacturers and building enterprises which have adopted this technology nevertheless still find themselves facing problems of acceptance of the material due to the absence of normative documents.

The present guide seeks to fill this gap. The guide is deliberately innovative in so far as it results from a global approach. Thus it goes much further than the classic, utilitarian aim of being of direct benefit to individual enterprises, and is positioned more at a level which is of interest to professional organisations as a whole.

In drafting the standards an innovatory process was introduced, favouring a pluri-disciplinary approach and involving a very large number of international experts and specialised institutions, representing all those involved in the building industry.

The standards were ratified as African Regional Standards under the auspices of the African Regional Organization for Standardization (ARSO) Technical Committee on Building and Civil Engineering (ARSO/TC3) after having satisfied ARSO's procedures for the approval of Regional Standards.

Although the normative documents have an official status of African Regional Standards, the influence of the guide is certain to be felt far beyond the geographical frontiers of the ACP countries.

The guide also testifies to the determination to respond to demands originating in the changing realities in the field. This standardisation corresponds perfectly to new needs in traditional building fields and helps the new technologies being implemented by ACP country enterprises to emerge.

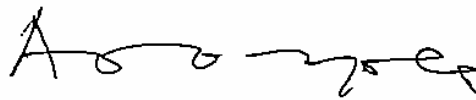

Dr. Oyejola O.A.
Secretary General
African Regional Organization
for Standardization



Houben H.
Research-Engineer
International Centre for
Earth Construction

Introduction

Unfired earth has been used for building construction since the most ancient times, as witnessed by traditional housing in many parts of the planet. Abandoned and forgotten with the advent of industrial building materials, and particularly concrete and steel, it is nowadays the object of renewed interest both in developing and in industrialised countries.

Earth construction is today developing a range of production techniques which span from the most rudimentary, manual, craft process to the most sophisticated, mechanised, industrial one. At the higher end of the spectrum, which has been the object of unprecedented scientific research, the production of earth materials is now on a par with other contemporary building materials. Amongst the most highly developed, compressed earth block technology is particularly noteworthy.

In the past, compressed earth blocks were produced by manual tamping in a wooden mould. In the 18th century, François Cointeraux, a Frenchman, designed the first press, the "Crécise". But it was not until the beginning of the present century that the principle of mechanical compression was taken up again, initially using manual presses equipped with heavy lids forced down onto the excess earth in the mould. Such machines were then motorised and equipment manufacturers went on to develop static energy presses in which the earth is compacted between two plates moving together. This process was that used to manufacture bricks for firing and was only moderately suitable.

It was not until 1952 that the first press specially designed for the production of compressed earth blocks came onto the market: the CINVA-RAM press, developed by the engineer Raul Ramirez at the CINVA centre of Bogota, Columbia. It was then that compressed earth block technology made an irreversible breakthrough. All over the world, major programmes for the construction of buildings using compressed earth block technology sprang up, especially in Latin America and in Africa: Sudan, Congo, Zaire, Guinea, Madagascar, Burundi, Rwanda, Zimbabwe. Alongside this activity, numerous scientific research and technological development programmes aimed to achieve a better grasp of the large scale production process. After a lull in the 60s, from the mid-70s onwards there was renewed interest, and during the 80s, the technology attracted the attention of construction industrials world-wide. The latter developed a whole new range of production equipment, including high speed industrial production chains. Simultaneously, many building enterprises were adopting earth building technology and its applications began to spread from private to public markets.

Since the 90s, CEB manufacturing technology has been widely disseminated amongst small and medium-sized enterprises in ACP countries. Architectural and technical offices in these regions are now interested in CEBs for planning construction projects, and public and private building companies have recently started to integrate the CEB in implementing housing programmes, demonstrating that this material is today accepted by building sector professionals.

The CDI attaches particular importance to developing this industry because it exploits locally available natural resources such as earth and because it creates jobs. In addition, the technology is easy to master and the level of investment is attainable for small and medium-sized industrial enterprises. In this respect, the CDI has assisted numerous ACP promoters, this assistance being provided at several levels:

- assessing the diagnosis of projects;

- assessing the setting up of production units;
- seeking European technical partners with equipment which is advantageous from an economical point of view and who are interested in transferring their skills and knowledge;
- training staff from several small and medium-sized enterprises in the context of demonstration projects;
- improving the technical and economic performances of CEB manufacturing units.

In addition to intervening in projects as such, the CDI, together with CRATerre-EAG, plays an active part in promoting the technology. Thus, an exhibition of some twenty panels presents the various types of block, the manufacturing technologies and a few experiences known in Africa. This exhibition has been shown at several industrial forums held in collaboration with the European Commission.

As far as publications are concerned, the CDI, with the help of CRATerre-EAG, has prepared a guide presenting an inventory of the equipment available in ACP and EU countries, selection criteria for manufacturing equipment, and the methodology to use in carrying out an economic feasibility study on the development of this product. 3,000 copies of this guide, which has proved very successful, have already been distributed amongst small and medium-sized enterprises, NGOs and development institutions in ACP countries.

It is now a question of knowing how to encourage enterprises to manufacture products which are certified to conform to standards with a view to reinforcing the use of CEBs in the construction sector. The guide entitled "Compressed earth blocks: standards" is part of this effort.

It aims to compensate for the relative absence of standards for the production and use of CEBs and presents a consistent series of standards which have the statute of African Regional Standards and which should ultimately facilitate the drafting of national standards. It is a practical document intended for construction industry professionals, but also a genuine "user's manual" aimed at those responsible for the standardisation of this material in their country.

The structure of the guide, which covers from the identification of raw materials to the finished building, should enable it to be suited to most contexts. These will dictate the relative importance of each technical normative element in the light of particular needs.

For each of these elements there should be corresponding performances or processes which make up a series of normative data (tests, products, etc.) which are distinct; but to promote adoption of innovative materials, systems and designs, they should be read globally. This enables more flexibility to be introduced, without losing sight of the main objectives of the standard, which are to protect the citizen and the quality of life.

Contents

STANDARDISATION PROCESS	9
Definition and aims of standardisation	11
Opportunity for standardisation	13
Recommendations on standardisation	15
Recommendations for the promotion of standards	17
Recommendations for certification	18
TERMINOLOGY AND CLASSIFICATION STANDARDS	19
ARS 670: 1996 - Compressed earth blocks Standard for terminology	21
ARS 671: 1996 - Compressed earth blocks Standard for definition, classification and designation of compressed earth blocks	31
ARS 672: 1996 - Compressed earth blocks Standard for definition, classification and designation of earth mortars	37
ARS 673: 1996 - Compressed earth blocks Standard for definition, classification and designation of compressed earth block masonry	41
COMPONENTS AND ELEMENTS STANDARDS	45
ARS 674: 1996 - Compressed earth blocks Technical specifications for ordinary compressed earth blocks	47
ARS 675: 1996 - Compressed earth blocks Technical specifications for facing compressed earth blocks	51
ARS 676: 1996 - Compressed earth blocks Technical specifications for ordinary earth mortars	56
ARS 677: 1996 - Compressed earth blocks Technical specifications for facing earth mortars	58
ARS 678: 1996 - Compressed earth blocks Technical specifications for ordinary compressed earth block masonry	61
ARS 679: 1996 - Compressed earth blocks Technical specifications for facing compressed earth block masonry	64

MANUFACTURING AND ASSEMBLING STANDARDS	69
ARS 680: 1996 - Compressed earth blocks Code of practice for the production of compressed earth blocks	71
ARS 681: 1996 - Compressed earth blocks Code of practice for the preparation of earth mortars	87
ARS 682: 1996 - Compressed earth blocks Code of practice for the assembly of compressed earth block masonry	99
 TESTING AND CONTROL STANDARDS	 113
ARS 683: 1996 - Compressed earth blocks Standard for classification of material identification tests and mechanical tests	115
 USEFUL PROMOTIONAL MATERIAL AND DOCUMENTS	 121
Promotional material	123
Technical documents	124
 OFFERS OF SERVICE	 127
CDI - Centre for the Development of Industry	129
CRATerre-EAG - International Centre for Earth Construction	132
ARSO - African Regional Organization for Standardization	134
 REGIONAL STANDARDISATION PROCEEDINGS	 137
Experts of the International Scientific and Technical Committee «Compressed earth block technology»	139
Experts of the Yaounde Seminar on the standardisation of compressed earth blocks	140
National standards bodies of the member states of ARSO	142

STANDARDISATION PROCESS

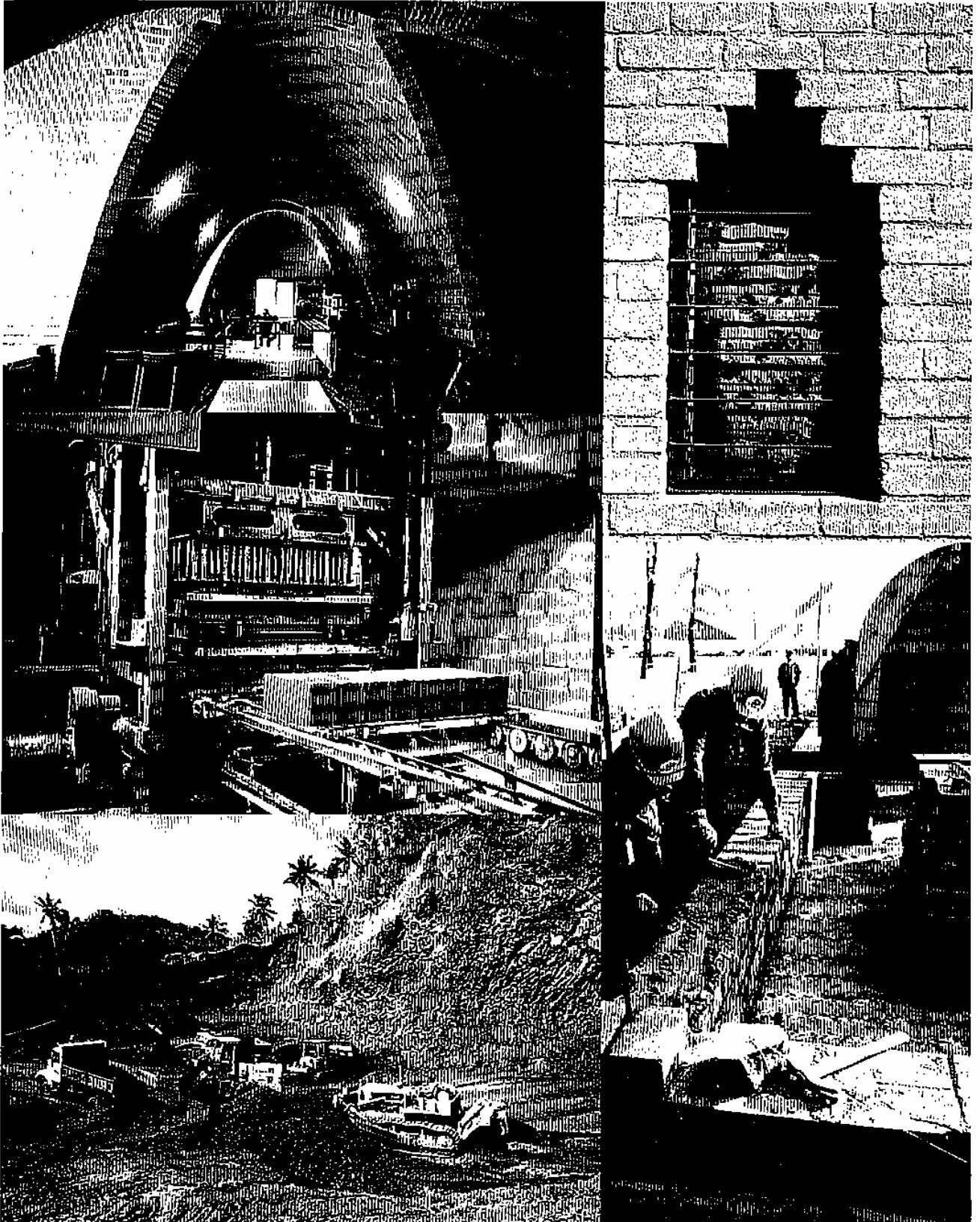

The standardisation concept which has been used in preparing the present guide conforms with ISO/IEC Guide 2, "Terminology - General Terms and their definitions concerning standardisation and related activities", fifth edition 1986.

The drafting and presentation of this guide have been realised in accordance with IEC/ISO Part 3 directives - "Drafting and presentation of International Standards", second edition 1989.

The recommendations on standardisation, promotion and certification were drawn up by the experts from the national standardisation organisations who attended the Yaoundé seminar, based on the texts of the document "Standard guidelines - Fibre or Micro Concrete Tiles", FCR/MCR Toolkit - Element 4. SKAT-ILO. BASIN. St Gallen/Geneva. Switzerland. 1994.

The texts which appear under an "ARS" chapter heading have been formally ratified by ARSO. The ratification process is detailed in the chapter "Regional standardisation proceedings".

Definition and objectives of standardisation

The International Standards Organisation (ISO) distinguishes between the terms «standards» and «normative documents» as follows:

- a standard is a: «document, established by consensus and approved by a recognised body, that provides, for common and repeated use, rules, guidelines or characteristics for activities or their results, aimed at the achievement of the optimum degree of order in a given context» and «should be based on the consolidated results of science, technology and experience, and aimed at the promotion of optimum community benefits»;
- a normative document is a: «document that provides rules, guidelines or characteristics for activities or their results» and therefore does not have the same scope, nor the same endorsement, but can become a «standard».

Various terms of the definition deserve comment.

«Consensus» does not necessarily imply unanimity, but «general agreement characterised by the absence of sustained opposition to substantial issues».

The objectives of standards are above all economic and social, to facilitate exchanges of goods and services and to protect the citizen (safety, product quality, etc.) and the quality of life (health, hygiene, environment etc.) This is why standards refer to «common and repeated uses» which therefore involve numerous partners and serve them as a means of reference for communication, for terminology, contracts, technical data, etc. This value as a reference rests of course on its scientific and technical viability for which approval by an organisation recognised for its moral authority and its respect for the rules on drawing up standards and on seeking consensus, is required.

The approval and the recognition of the standard, both by the parties concerned and by the moral authority, ensure «an optimum degree of order» required for exchanges and contractual relationships, and therefore for the industry and the economy. This «order» is of course linked to «a given context» and a given moment, which means that the document is not static, but rather one which is regularly re-examined and if necessary revised.

Standards thus enable technology dissemination from the relevant technical and economic collective body to all enterprises, providing the basis for replicable technical solutions and thus the gradual building up of a common «technical culture» which aims to remove various technical obstacles. This is particularly relevant in developing new products and in winning new markets.

On the basis of these objectives, innovation is clearly important and the standard should not prevent it from occurring. It is, however common to believe that a standard is rigid and constraining. It might indeed seem paradoxical to ensure «an optimum degree of order» and to «stimulate innovation», but to innovate it is vital to know and to use that which exists, and next to have the tools and the aids to enter the market in satisfactory conditions of competitiveness and commercial success.

For this to occur, everything depends on the type of standards the community has and it is important to distinguish between the «means» standard and the «results» standard. The former, which is the most classic, describes in practical terms the means to be used to achieve an objective, it is a little akin to a manufacturing guide, but it can make the technique inflexible.

The latter determines the result to be achieved (characteristics, performance, etc.) but leaves the service provider totally free to choose the means employed. Contrary to the former, there is no danger of its handicapping progress and it encourages innovation, but there is nevertheless a risk that this freedom to choose the means employed might lead to reinventing that which already exists and consequently using costly and complex means. A standard allowing for innovation should therefore describe means in such a way as to allow choice, rather than to impose them.

Opportunity for standardisation

The transition from traditional, rural societies to industrial, urban ones has significantly transformed relationships within societies, making exchanges more fragmented and complex. The way exchanges have been transformed is particularly apparent in technical areas which were the first to undergo the effects of the «industrial revolution» or of «modernity».

Traditional systems involved few operators in the act of building: one could be designer, materials producer and builder all at once, or if clients did turn to a «professional», it was for a precise task of which they themselves had some experience, since all «citizens» of a given area shared a single technical culture. This kind of exchange, which still sometimes occurs, is inevitably tending to disappear as a result of a greater complexity of technical cultures which have become difficult to grasp in their entirety, and as a result of the greater number of parties involved. Apart from the user, there are now building material manufacturers, wholesalers and retailers, building companies and sub-contractors, building societies, professional consultants, funding organisations, etc. In the face of this complexity, technical reference documents, standards, have become vital for exchanges between all these operators to occur. Such documents are in fact often produced on the initiative of the operators themselves.

As far as building materials such as the compressed earth block are concerned, the need for standards comes virtually unanimously from producers and/or users who want to prove that this material, although it has its roots in tradition, can take its rightful place in current construction practices.

Thus producers and users often find themselves confronted by technical hurdles, as for most new technologies, above all as a result of ignorance, since they are not yet part of the «common technical culture».

Designers cannot use the material since they do not know its characteristics and performances; construction companies do not know how it should be used; inspectors do not know how to test and measure its performances; and banks and insurance companies, without inspectors paving the way, cannot underwrite loans and 10-year guarantees for building works, etc. As a result, the only avenue still open to producers and/or builders is to ensure for themselves the promotion and the credibility of this technology. For example, building at one's own expense test walls to reassure the client and the inspector, or following expensive and complex test procedures, relating to other building materials, because existing standards do not provide any others and are applied with no regard for the production and utilisation context.

Referring to ISO guidelines on standards in the construction field, it can be noted that: «any standardisation in the field of construction should recognise that a building is built, above all, to meet the requirements of people particularly with regard to their health, comfort and safety. The best solution, ultimately, consists in expressing international construction standards as far as possible in terms of performance requirements for building elements, components and materials,» and particular attention is drawn to the fact that requirements should be formulated in this order rather than the opposite one.

This means focusing first on results (the building) and then on the means to achieve them (materials, production and construction, etc.), but if only the means are specified, there is a danger that it might become impossible to respect both the standard and the users' requirements.

For example, a restrictive specification stipulating very high compressive strength, when dealing with a simple, single-storey building, runs the risk of forcing the use of certain materials which might be out of the financial reach of the majority of the population.

The same ISO guidelines also state: «international construction Standards should still take account of various climatic or regional conditions, and notably of the skills available and of the various stages of technical and economic development. It is appropriate, as often as possible, for international construction standards to include different levels of requirements to be applied in different regions in the light of the conditions predominating».

It is therefore fairly clear that normative documents on compressed earth blocks are tools for promoting and defending this relatively new technology and that if demand emerges and is not met, the absence of normative documents would penalise the various operators who had invested or who wished to invest in it, in whatever particular way.

Naturally, for them to be effective and operational, such documents must follow the various principles stated above and which can be briefly summarised as follows:

- they must be precise, i.e. specific to this material and not a transposition of standards intended for other materials;
- they must be established by consensus, by the operators involved as a whole, whether public, private, technical, user, financial, etc.;
- they must be realistic, taking account of climatic and regional conditions (both technical and economic);
- they must be comprehensible to those qualified persons who were not involved in drawing them up.

Recommendations on standardisation

Drawing up standards for products, goods and services falls under the responsibility of the National Standards Body (NSB), which uses a procedure valid for all products, including compressed earth blocks (CEBs), earth mortars (EMs) and compressed earth block masonry (CEBM).

Recommended method

The recommended method is known as the «Technical Committee Method».

In the light of needs expressed in a specific area, the National Standards Body (NSB) sets up a technical committee (TC). If necessary, sub-committees (SC) and working groups (WG) are also formed to carry out the work of the technical committee. These committees and working groups are made up of representatives of producers, users, technical teaching staff, researchers, professionals and various government structures, so that their conclusions are realistic and meaningful, and reflect the diversity of the environment. The NSB acts as the secretariat and co-ordinates the work of the TC.

The method consists of the following phases:

Phase 1: Feasibility study and programme definition

The NSB plans its work programme taking account of the requests or proposals forwarded to it by various parties. This programme reflects the needs and concerns of industry, of commerce, of users, of technical teaching staff, of researchers, of professionals and of administrators. The other factors the NSB has to take into account are notably:

- the state of development of the technique, including the most recent scientific and technological programmes, as well as changes in the design of products and materials;
- the availability of resources in the country with regard to technology, production process and materials;
- hygiene and public safety;
- national economic development objectives.

Phase 2: Preparation

The NSB prepares or has prepared by a technical associate a draft standard using existing texts at national level, the national standards of other countries, regional and/or international standards and in consultation with the sectors involved. This text, which forms the «base document», is submitted to the TC for detailed deliberation. Once a consensus on the essential points has been achieved, the TC prepares an «amended document».

Phase 3: Public enquiry

The project is presented to a wider audience, (ministry representatives, various government and private organisations, research institutes, housing companies, funding bodies, materials manufacturers, entrepreneurs, technical centres, laboratories, teaching institutions, technical control organisations, insurance companies, etc.) in order to obtain wider comments and suggestions: the audience consulted is then broadened to include the associates of the partners involved, including national and foreign practitioners.

Phase 4: Ratification

Following consideration and objective evaluation of the comments and suggestions resulting from the public enquiry, the «final standard» is drafted and submitted for ratification as a national standard to the relevant authorities (the department responsible for standards within the relevant technical department).

N.B. National standards can be obligatory for reasons of safety, health, protection of the environment, etc.

Phase 5: Publication

The national standard is then edited and published in the official record for generalised distribution.

Recommendations for the promotion of standards

To promote CEB standards, all the institutions involved in this technology should take concerted action.

Training

An efficient way of making the standard familiar and ensuring that it is used is to regularly refer to it during training programmes. Manuals and other teaching materials should also be adapted in consequence.

Publicity

Distributed through appropriate channels, articles and adverts in specialised journals, radio broadcasts and video spots are all important ways not to be neglected to make the standard known.

Events

Holding events, for example combined with professional meetings or exhibitions, can also be a way of transmitting information to a wide audience.

Institutionalisation

The NSB should lead the authorities involved to amend their national building regulations and other legislative documents so that these take CEBs into account. By doing so, these authorities help to reinforce the standard.

City authorities should be encouraged to modify their building regulations by introducing the use of CEBs into relevant legislation.

To facilitate this, it can be useful to invite the authorities concerned to take part in study tours, in order to familiarise them with CEBs and with current developments.

Recommendations for certification

Only the strict application of standards to check all CEB materials at the point of production will enable a consistent and reliable quality to be obtained in a given country. This is vital to win user confidence.

Standards should serve as a reference for:

- establishing and defining a certification procedure;
- checking production and product sales;
- drafting submission documents and purchasing contracts.

Proposed certification method

The NSB should run a certification system allowing producers to use a NS label (National Standard). This label can be awarded only if production respects a number of requirements intended to guarantee the quality of the finished products. This authorisation is awarded after thorough and regular inspection of an enterprise.

The inspection should review production, monitoring and evaluation mechanisms, quality control equipment and procedures, staff skills, and any other factor enabling an appreciation of whether a producer is capable of respecting the standards. During the inspection, the NSB should provide as often as necessary technical advice allowing the producer to improve current production and quality control.

Thus, when a product is labelled NS, this means that it is good quality, reliable and strong.

The label of conformity to standards affixed to products and/or packaging should give the following information:

- name of producer;
- production label or other means of identification;
- the number of the standard;
- the date of production.

On request, the producer should provide a certificate attesting that the products conform to the standard in question.

Product control and laboratory accreditation

To support the certification label system and to encourage the development of standards, the NSB should work in collaboration with control laboratories.

These public or private laboratories work in collaboration with the NSB on product control. They should be the object of an accreditation procedure taking account of their skills, their integrity and their desire to work in close connection with the NSB.

TERMINOLOGY AND CLASSIFICATION STANDARDS

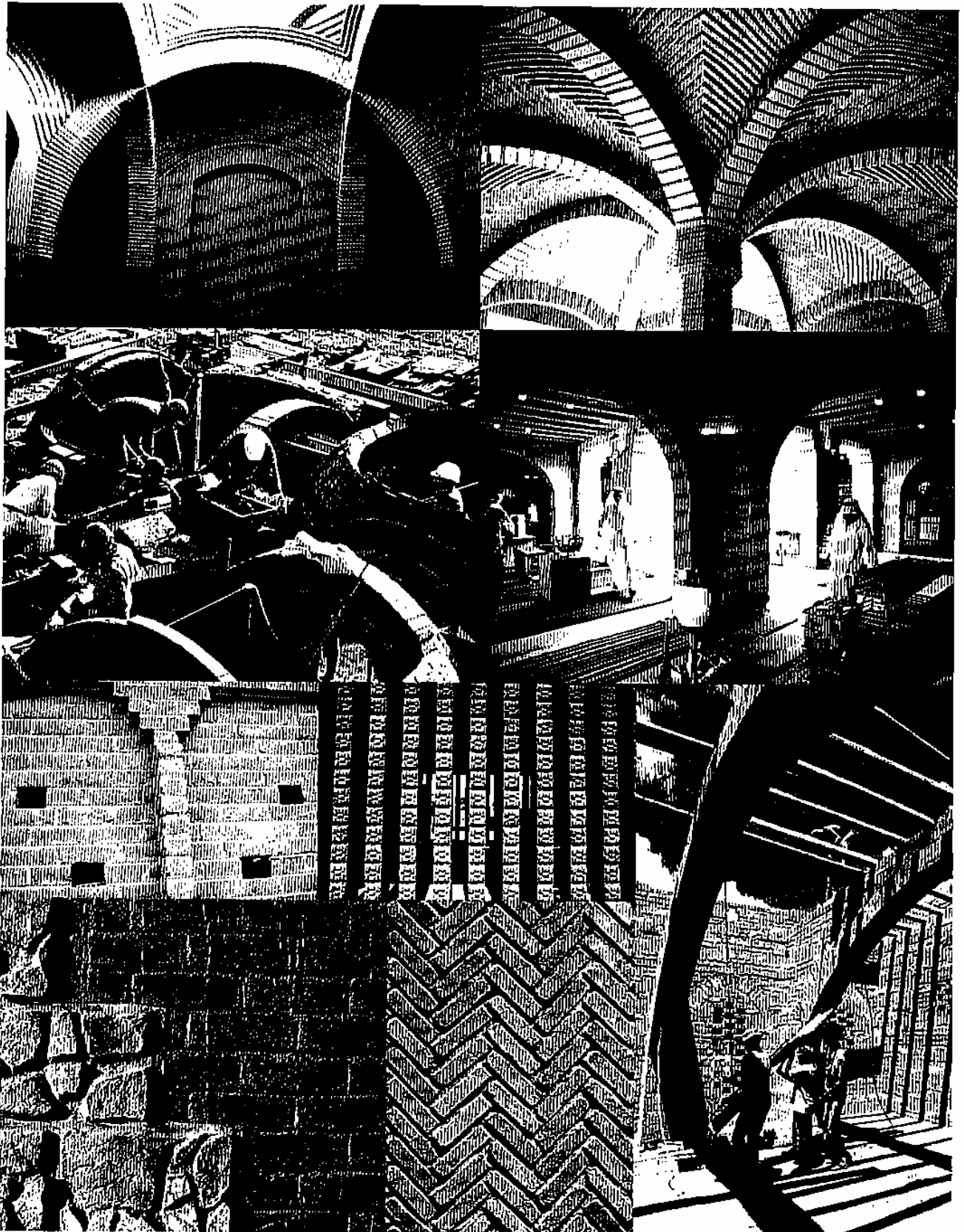

The terminology of compressed earth block technology is very similar to the classic terminology for small masonry elements which is generally perfectly suitable.

To designate the specific product which is the object of this guide, the experts as a whole opted for the term "Compressed Earth Blocks" (CEBs). This generic term includes all the variations of this product, whether or not the earth is stabilised.

It should be noted, however, that the literature abounds with other designations, all referring to the same products: Stabilised soil-cement, Stabilised soil blocks (SSB), Stabibloc, Terracrete, Soilcrete, pressed soil bricks, Geocrete, etc.

ARS 670: 1996 - Compressed earth blocks Standard for terminology

1 General

1.1 Object

The aim of the present standard is to define the principle terms applying to compressed earth block technology (CEB).

1.2 Fields of application

The terms defined by the present standard are applicable in drawing up all technical, administrative and contractual documents relating to compressed earth block technology and relate both to public and to private contracts.

2 Terms applicable to compressed earth blocks

2.1 Definition

Compressed earth blocks (CEBs) are masonry elements, which are small in size and which have regular and verified characteristics obtained by the static or dynamic compression of earth in a humid state followed by immediate demoulding.

Compressed earth blocks generally have a rectangular parallelepiped format and are full or perforated with vertical and/or horizontal indentations.

Compressed earth blocks are principally made of raw earth and owe their cohesion in a humid state and in a dry state essentially to the clay fraction within the earth; an additive can, however, be added to the earth to improve or enhance particular characteristics of the product (see 3.1.2).

The final characteristics of CEBs depend on the quality of the raw materials used (earth, additive) and on the quality of the execution of the various manufacturing stages (preparation, mixing, compression, curing).

Note: this definition therefore excludes blocks obtained by extrusion, as well as agglomerated products where the chemical binder plays an essential part in ensuring cohesion when dry.

2.2 Description

The most common type of CEB can be described geometrically stating its format. The format of the product described consists of its general shape, its principal dimensions and the nature of any indentations (hollows, perforations etc.) incorporated into the product.

The most common format is a rectangular parallelepiped (or prismatic) format with a length (l), a width (w) and a height (h). Giving these three dimensions in this order (l, w, h) is sufficient for their use.

Non parallelepiped rectangular formats require a fuller description (cylindrical, conical, hexagonal, wedge-shaped, in the form of a truncated cone, etc.). The format used for the description is the nominal format which takes into account the manufacturing dimensions.

The format may be principal or secondary. The principal format or common format corresponds to the basic format from which secondary formats are obtained, these being merely fractions or multiples of the basic format in relation to its length. The most frequently found secondary formats are the «3/4», the «1/2» and the «1/4» the respective lengths of which are:

- $l_{3/4} = (l_{4/4} - tm/3)_{3/4}$
- $l_{1/2} = (l_{4/4} - tm)_{1/2}$
- $l_{1/4} = (l_{4/4} - 3tm)_{1/4}$

where tm is the thickness of the vertical joint. There are also CEBs reduced by half in height.

Secondary format CEBs are required to ensure bonding continuity throughout the built structure, for example at wall corners, and at the intersections of walls and partitions.

Secondary format CEBs are obtained either directly by manufacturing, or cut at the moment of use.

The «nominal format» should not be confused with the «work format» which corresponds to a description using real dimensions to which a corresponding joint thickness has been added.

The work format is therefore a unit of measurement for practical use enabling the dimensions of a built structure to be rapidly calculated. To recapitulate:

- nominal format: (l, w, h)
- work format: (l + tm, w + tm, h + tm)

Table 1 — Example relating to the height of blocks

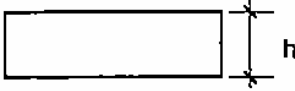
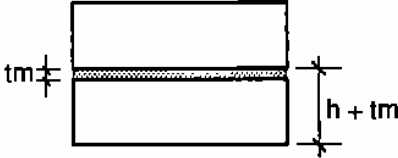
NOMINAL FORMAT	WORK FORMAT
 <p style="text-align: center;">Ex: $h = 9 \text{ cm}$</p>	 <p style="text-align: center;">Ex: $h + tm = 9 + 1,5 = 10,5 \text{ cm}$</p>

The nominal format is the one normally used and in the event of any danger of confusion it is recommended that the nature of the format being used should be specified.

2.3 Description of the parts of CEBs

The prismatic block has 6 faces, each of which has a name:

- 2 faces are known as surface «stretchers» ($l \times h$);
- 2 faces are known as surface «headers» ($w \times h$);
- 1 face is known as the «laying face» ($l \times w$), being the upper face of the CEB when laid;
- 1 face is known as the «bed face» ($l \times w$), being the lower face of the CEB when laid.

Table 2 — CEB faces

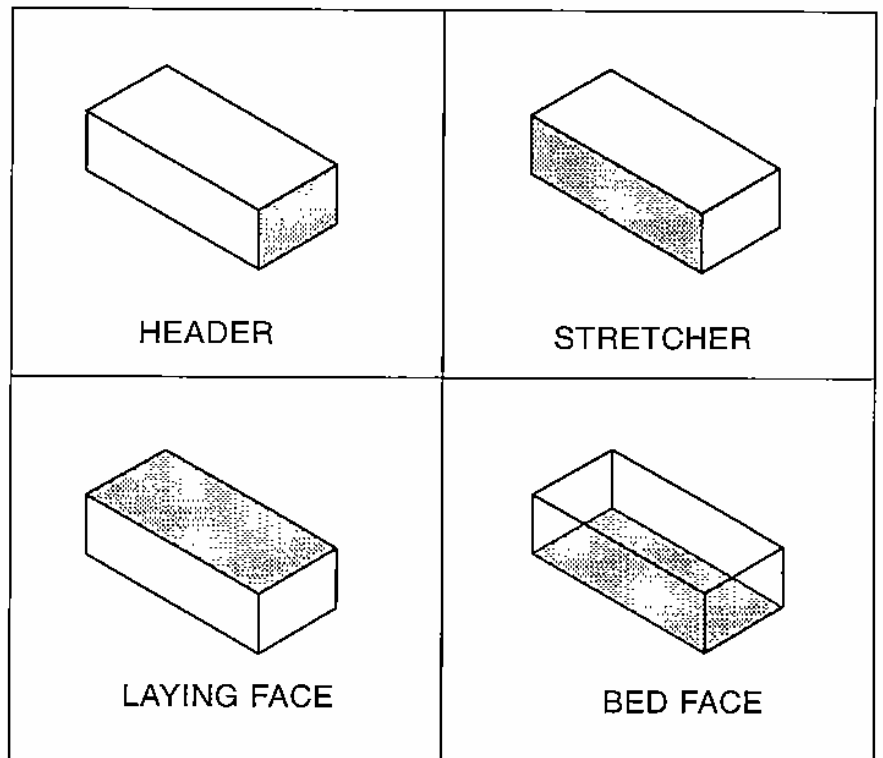

The details describing a CEB should include the following values:

- gross section: $l \times w$ (l and w measured on the same plane);
- net section: gross section less any hollow;
- bed section: surface common to the laying and the bed faces when superimposed in contact with the mortar joints and capable of transmitting the load.

Table 3 — CEB sections

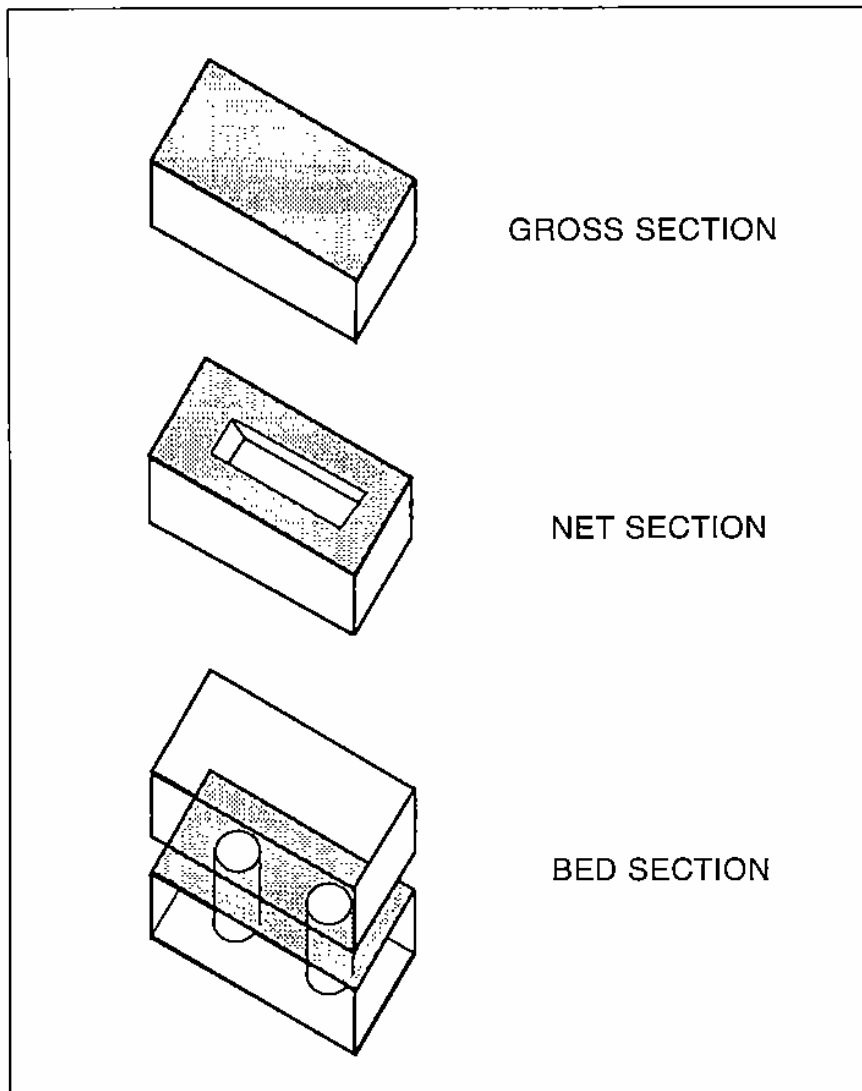

3 Terms applicable to compressed earth block production and production equipment

3.1 Terms applicable to CEB constituents

3.1.1 Earth

Earth intended for CEB construction designates the basic material made up essentially and in carefully controlled proportions of the following components, before any mixing with an additive or with water: gravel, sand, silt and clay. These components can be defined using a metric classification, or with regard to the fines, by their mineralogical nature.

The metric classification is as follows:

— gravel fraction:	coarse gravel	-	60 mm to 20 mm;
	medium gravel	-	20 mm to 6 mm;
	fine gravel	-	6 mm to 2 mm;
— sand fraction:	coarse sand	-	2 mm to 0.6 mm;
	medium sand	-	0,6 mm to 0,2 mm;
	fine sand	-	0,2 mm to 0,06 mm;
— silt fraction:	coarse silt	-	0.06 mm to 0.02 mm;
	medium silt	-	0,02 mm to 0,006 mm;
	fine silt	-	0,006 mm to 0,002 mm;
— clay fraction:	passes the	-	0.002 mm sieve.

There are other classifications which are also acceptable.

Coarse material (gravel and part of the sand fraction) consists of components with a diameter in excess of 0.08 mm. Coarse material provides the stable "skeleton" of CEBs thanks to its internal friction and its inertia.

Fine material (a part of the fine sand fraction, silt and clay) consists of components the diameter of which is less than or equal to 0.08 mm. From a mineralogical point of view, the notions of clay and of silt are not restricted to the metric values given above. Understanding the mineralogical nature of fines may be vital when selecting types of earth.

Fines fill in the voids in the "skeleton". Clay and part of the silt fraction provide the cohesion of CEBs because they act as binders.

3.1.2 Additive

An additive is a substance added during manufacture, intended to improve the final characteristics of the CEB or to enhance particular characteristics.

The most common additives are stabilisation products, known as stabilisers, such as cement, lime, pozzolonas, etc. intended to neutralise the sensitivity to water of the fine fraction and thus to maintain cohesion at an acceptable level even in a humid state. But other additives can also be used to modify other characteristics such as colour (colouring agents), tensile strength and reducing shrinkage cracks (fibres), etc.

3.1.3 Filler

A filler is a granular material, generally of a sandy type, employed as an additive in types of earth which contain too great or too active a silt and/or clay fraction.

3.1.4 Mix

The mix is the material obtained by adding additives and/or filler and water to the earth, preparatory to being introduced into the press for the manufacture of the CEB.

3.2 Terms applicable to the production of compressed earth blocks

3.2.1 Preparing the earth

This consists of the following operations:

- drying;
- screening.
- pulverising;

3.2.1.1 Screening

This operation is intended to eliminate all undesirable components (roots, leaves, etc.) together with any components with a diameter greater or lesser than that required. This operation also enables the earth to be loosened in a uniform manner.

3.2.1.2 Pulverising

This operation is intended to break down lumps made up of coarse material and/or fines. It can also be used to split coarse material to reduce it to smaller diameter aggregates.

3.2.2 Mixing

This is a series of technical operations aimed at making the prepared earth, to which additives and/or a filler may have been added, homogeneous. Mixing most often takes place in two stages: dry mixing before adding water and wet mixing after adding water. There may also be a third stage, after a given reaction time, which consists in subjecting the mix to a further phase of stirring.

3.2.3 Retention time

Retention time is the delay between the start of wet mixing and the compression of the earth.

3.2.4 Compression

Compression is the operation which consists in compressing the material in a confined space known as a mould using a static or dynamic mode; compression is followed by immediate demoulding, freeing the shaped block.

3.2.5 Curing

Curing is the period following compression during which two types of phenomena principally occur. These can be differentiated as follows:

- physicochemical reactions between the various components of the mix and above all between the earth and the additives resulting in the stabilisation of the block; during this phase, conditions of relative hygrometry and of heat are crucial and require careful attention;
- drying which consists in the gradual removal of manufacturing humidity by evaporation.

3.3 Terms applicable to production equipment

3.3.1 Preliminary note

All production operations can be carried out manually with simple tools or using manual or motorised mechanical equipment.

3.3.2 Earth preparation equipment

Preparation equipment includes:

- screens, to remove components with too large a diameter;
- pulverisers, which allow the particle size of coarse components to be reduced or silt and clay aggregates to be broken down without affecting the particle size distribution.

3.3.3 Mixing equipment

Mixing is carried out using a mixer. Mixers can be planetary, where the mixing system is mounted on a vertical axis, or linear, where the mixing system is driven by a horizontal axis.

3.3.4 Presses

Presses are classified using several criteria:

- a) *the energy source*: manual or motorised (with a distinction between thermal and electric motors);
- b) *the system by which the energy is transmitted to the moulding system*: mechanical, hydraulic, or combined.

3.3.5 Specific characteristics of presses

In describing presses, certain specific criteria are used.

- a) *Compression action*: this is the very principle of the operation of the compression system. Compression may be static, dynamic by vibration or dynamic by impact.
- b) *Usable force*: the force potentially available to compact the earth.
- c) *Compression pressure*: the pressure theoretically applied to the mix and which expresses the ratio of usable force to the surface to which it is applied; compression pressure is classified as follows:

- very low pressure: 1 to 2 N/mm²;
- low pressure: 2 to 4 N/mm²;
- medium pressure: 4 to 6 N/mm²;
- high pressure: 6 to 10 N/mm²;
- hyperpressure: 10 to 20 N/mm²;
- megapressure 20 N/mm² and over.

It should be noted that the highest compression pressures are not necessarily the most efficient.

- d) *Pressure at the end of compression*: the pressure actually applied to the mix at the end of compression.

e) *Dynamic effect coefficient*: the effect, on static compression presses, due to the inertia of the lever movement of the machine, which increases the pressure at the end of compression.

f) *Compression mode*: the principle of spreading the pressure across the mix. In simple compression, pressure is transmitted by displacing a single plate onto the laying or the bed face. In double compression, pressure is applied by displacing both plates onto the laying and the bed face simultaneously or alternatively.

g) *Compression ratio*: the ratio between the depth of the press mould before compression and the depth at the end of compression (which corresponds to the height of the CEB product).

h) *Output*: theoretical output corresponds to the sum of the number of CEBs produced per cycle, by number of cycles (filling, compression, demoulding) per hour; practical output corresponds to the theoretical output adjusted for estimated down time (machine maintenance etc.); actual output is the output measured in the context of normal activity.

3.4 Terms applicable to delivery conditions

3.4.1 Order

3.4.1.1 Ordering earth

The order specifies the designation of the earth (gravely earth, sandy earth, clayey earth, etc.), the quantity, the place of delivery, and the procedure for accepting or rejecting delivery. The order may also specify the location of the quarry and the depth of the quarrying operation.

3.4.1.2 Order for CEBs

The order specifies the designation of the CEBs, the quantity, the delivery location, and the procedure for accepting or rejecting delivery.

3.4.2 Supply

The quantity of merchandise corresponding to one and the same order.

3.4.3 Delivery

The quantity of merchandise delivered or intended to be delivered on one single occasion, whatever the number and the nature of the means of transport used.

3.4.4 Lot

The quantity of merchandise serving as a basis for determining samples for testing.

3.4.5 Taking delivery

A series of operations enabling the conformity of the merchandise to be checked against the specifications of the standard.

4 Terms applicable to construction with CEBs

Compressed earth blocks being masonry elements, when referring to their use, one therefore applies the common terminology of traditional masonry with thick mortar joints (around 15 mm).

4.1 Earth mortar

An earth mortar (EM) is a mortar used for compressed earth block masonry of a traditional type using thick mortar joints.

An earth mortar consists principally of raw earth and water and owes its cohesion in a humid or a dry state essentially to the clay fraction of the earth; an additive and/or a filler can, however, be added to the earth to improve or enhance particular characteristics of the mortar.

4.2 Compressed earth block masonry

Compressed earth block masonry (CEBM) is masonry of a traditional type using thick earth mortar joints.

5 Terms applicable to assessing the characteristics, performance and suitability for use of CEBs

To assess the characteristics, performance and suitability for use of compressed earth blocks, one should use the terminology commonly used for other small masonry elements, excluding the elements provided in the present standard relating to terminology.

6 Symbols and units

6.1 Units of measurements

Table 4 — Symbols and basic units of measurement

Symbols	English	French	SI Units		Units used in the building sector
L	Length	Longueur	metre	m	m, cm, mm
F	Force	Force	newton	N	MN, kN, N
σ	Pressure, Stress	Pression, Contrainte	pascal	N/m ²	MPa = N/mm ² = MN/m ²
m	Mass	Masse	kilogramme	Kg	t, kg, g
t	Temperature	Température	degrees Celsius	°C	°C
T	Time	Temps	seconds	s	h, min, s

6.2 General notations

Table 5 — Symbols and units of general notations

Symbol	English	French	Formula	Unit
Ph	Humid weight	Poids humide		g, kg
Pd	Dry weight	Poids sec		g, kg
Pw	Weight of water	Poids d'eau		g, kg
V	Volume of sample	Volume de l'échantillon		cm ³ , m ³
W	Water content	Teneur en eau	$W = \frac{Pw \times 100}{Pd}$	% weight
Wopt	Optimum water content	Teneur en eau optimale		% weight
γ _d	Dry density	Masse volumique sèche (Densité sèche)	$\gamma_d = \frac{Ph}{V \times (1 + W)}$	kN/m ³
γ _h	Apparent density	Masse volumique apparente (Densité apparente)	$\gamma_h = \frac{Ph}{V}$	kN/m ³
γ _s	Solid grains density	Masse volumique des grains solides (Densité des grains solides)	γ _s = 26.5	kN/m ³
Pstab	Weight of binder	Poids de liant		g, kg
Stab	Binder content	Teneur en liant	$Stab = \frac{Pstab \times 100}{Pd}$	% weight
D	Largest grain diameter	Diamètre du plus gros grains		mm
0/d	Grain fraction between 0 and dmm	Fraction granulométrique entre 0 et d mm		
LL	Liquid limit	Limite de liquidité		% weight
PL	Plastic limit	Limite de plasticité		% weight
I _p	Plasticity index	Indice de plasticité	I _p = LL - PL	
VBS(0/d)	Methylene blue value of the 0/d fraction of soil	Valeur de bleu de méthylène de la fraction 0/d du sol		
VBS total	Methylene blue value of the entire soil	Valeur de bleu de méthylène totale du sol		
l	Length of CEB	Longueur du BTC		mm, cm
w	Width of CEB	Largeur du BTC		mm, cm
h	Height of CEB	Hauteur du BTC		mm, cm
t _m	Thickness of mortar	Épaisseur du mortier		mm, cm
f _b dry	Dry compressive strength of CEB tested in homogeneous conditions	Résistance à la compression sec du BTC testée dans des conditions homogènes		N/mm ²
f _b ^t dry	Dry tensile strength of CEB	Résistance à la traction sec du BTC		N/mm ²
f _b wet	Wet compressive strength of CEB	Résistance à la compression humide du BTC		N/mm ²
f _b ^t wet	Wet tensile strength of CEB	Résistance à la traction humide du BTC		N/mm ²
f _m dry	Dry compressive strength of mortar	Résistance à la compression sec du mortier		N/mm ²
f _m ^t dry	Dry tensile strength of mortar	Résistance à la traction sec du mortier		N/mm ²
E _b	Young's modulus of CEB	Module d'Young du BTC		N/mm ²
ν _b	Poisson's ratio of CEB	Coefficient de Poisson du BTC		
E _m	Young's modulus of EM	Module d'Young du MT		N/mm ²
ν _m	Poisson's ratio of EM	Coefficient de Poisson du MT		
h _{ef}	Effective height of wall	Hauteur effective du mur		cm, m
t	Thickness of wall	Épaisseur du mur		cm, m
f _k	Dry characteristic compressive strength of masonry	Résistance nominale à la compression sec de la maçonnerie		N/mm ²
f _{vk}	Dry characteristic shear strength of masonry	Résistance au cisaillement sec de la maçonnerie		N/mm ²
f _{vk0}	Dry characteristic shear strength of masonry at zero precompression	Résistance au cisaillement sec de la maçonnerie sans précompression		N/mm ²

ARS 671: 1996 - Compressed earth blocks Standard for definition, classification and designa- tion of compressed earth blocks

1 General

1.1 Object

The aim of the present standard is to define compressed earth blocks (CEBs), to classify them according to their typology, their appearance, their conditions of use, and to determine the categories into which they fall as well as their designations.

1.2 Fields of application

The definitions, classifications and designations of the present standard are applicable in establishing any technical, administrative or contractual document relating to compressed earth block technology, and relate both to public and to private contracts.

The standard applies exclusively to CEBs intended for the realisation of simple built structures in common masonry with thick mortar joints (walls, partitions, piers, small lintels, arches, vaults, domes, etc.) and of any similar built structure.

The standard does not apply to CEBs used for flooring or tiling, nor to CEBs designed to be assembled dry, interlocking, using glue-mortar, or used in reinforced masonry.

The standard is not applicable in areas subject to earthquakes, floods or cyclones to an extent that requires the application of appropriate rules in order to avoid major damage.

2 Definition of CEBs

Compressed earth blocks (CEBs) are masonry elements, which are small in size and which have regular and verified characteristics obtained by the static or dynamic compression of earth in a humid state followed by immediate demoulding.

Compressed earth blocks generally have a rectangular parallelepiped format and are full or perforated, with vertical and/or horizontal indentations.

Compressed earth blocks are made principally of raw earth and owe their cohesion in a humid state and in a dry state essentially to the clay fraction within the earth; an additive can, however, be added to the earth to improve or enhance particular characteristics of the product.

Note: this definition therefore excludes blocks obtained by extrusion, as well as agglomerated products where the chemical binder plays an essential part in ensuring their cohesion when dry.

3 Classification of CEBs

3.1 Classification of CEBs by type

Compressed earth blocks are classified according to several types.

3.1.1 CEB type 1

Full rectangular parallelepiped format with no indentation on any face.

3.1.2 CEB type 2

Full rectangular parallelepiped format with an indentation on one or both of its larger faces (laying and bed face). Various common indentations include:

- hollows (frogs), which makes the CEB lighter and easier to handle;
- slight horizontal grooves allowing a better bond with the mortar;
- horizontal grooves to receive thin construction elements, such as pipes, electric cables etc.;
- deep horizontal grooves to receive construction elements such as ring beams etc.;
- lateral grooves enabling claustra-work structures to be built without needing to use special bonding.

3.1.3 CEB type 3

Full rectangular parallelepiped format with one or more indentations (e.g. hollows, rounded or chamfered corners, etc.) on the stretcher or header faces or simultaneously on several faces.

Indentations in the vertical (header or stretcher) faces of CEBs are most often grooves intended to receive thin construction elements.

3.1.4 CEB type 4

Rectangular parallelepiped format with holes or perforations between the largest faces. Depending on the section of the holes and on how many there are, one refers to perforated blocks (a few, small holes), hollow blocks (a few, large holes) or alveolar blocks (many small perforations).





3.1.5 CEB type 5

Rectangular parallelepiped format with holes or perforations in combination with indentations on its larger faces (laying face and bed face).

3.1.6 CEB type 6

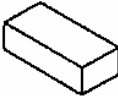
Rectangular parallelepiped format with holes or perforations and with indentations on the stretcher and header faces sometimes in combination with indentations on its larger faces.

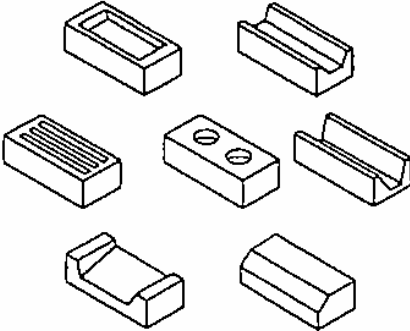
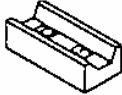
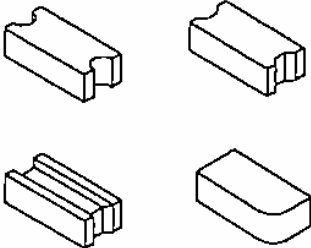
Table 1 — The 6 types of CEB

		FULL	PERFORATED
RECTANGULAR PARALLELEPIPED FORMAT CEB	SIMPLE	<p>CEB type 1</p> 	<p>CEB type 4</p> 
	WITH HORIZONTAL IDENTATION	<p>CEB type 2</p> 	<p>CEB type 5</p> 
	WITH VERTICAL AND VERTICAL + HORIZONTAL IDENTATION	<p>CEB type 3</p> 	<p>CEB type 6</p> 

3.2 Classification according to use

CEBs can be classified into two groups according to use:

- ordinary CEBs;
- facing CEBs.

3.2.1 Ordinary CEBs (CEB O)

These are CEBs used in masonry structures intended to be covered by some form of protection.

3.2.2 Facing CEBs (CEB F)

These are CEBs used in masonry structures intended to remain visible. One can differentiate between:

- normal facing CEBs (CEB NF);
- fine facing CEBs (CEB FF).

The difference between these two facing CEBs is restricted to their appearance without affecting their other characteristics.

3.3 Classification according to field of use

The fields of use of CEBs within masonry structures are classified according to two types of constraints which can occur simultaneously:

- mechanical constraints;
- environmental constraints.

3.3.1 Mechanical constraints

These are defined according to three categories of resistance:

- *category 1*: structural elements which are not load-bearing and structural elements capable of withstanding limited external (live) loads (e.g. fill-in in a load-bearing structure) (e.g. boundary wall) (e.g. a single-storey building made of load-bearing structural elements);
- *category 2*: structural elements capable of withstanding important external (live) loads (e.g. a two storey building with accessible terrace made of thin load-bearing structural elements);
- *category 3*: structural elements capable of withstanding high external (live) loads (e.g. a three storey public building made of thin load-bearing structural elements).

3.3.2 Environmental constraints

These are defined according to 4 categories of environment:

- *category D*: structural elements located in a dry environment with no danger of being wet (e.g. internal partitions) (e.g. external walls which are not exposed or which are protected from water damage);

- *category B*: structural elements capable of withstanding water damage by lateral spraying
(e.g. lateral walls exposed to rain)
(e.g. bathroom walls being splashed);
- *category C*: structural elements capable of withstanding water damage by vertical penetration (capillary rise, penetration by gravity, suction or internal condensation)
(e.g. external walls unprotected from capillary rise)
(e.g. internal walls unprotected from water leaking through the roof);
- *category A*: structural elements capable of withstanding mechanical abrasion (impact, rubbing or wind damage)
(e.g. corners or walls subject to impact)
(e.g. areas subject to rubbing by animals)
(e.g. areas subject to sand storms).

4 Designation of CEBs

The designation of compressed earth blocks includes the following indications, to be given in the same order:

- product designation
CEB for «compressed earth block»;
- designation according to use:
O for «ordinary»
F for «facing»
NF for «normal facing»
FF for «fine facing»;
- designation according to mechanical constraints:
1 for «category 1»
2 for «category 2»
3 for «category 3»;
- designation according to the constraints of the hygrometric environment:
D for «category D»
R for «category R»
C for «category C»;
- designation according to the constraints of the mechanical abrasion environment:
A for «category A».

The CEB designation may also include the following indications to be given in the same order:

- type of CEB;
- manufacturer's trade name or mark;
- the manufacturing dimensions (L, w, h);
- colour;
- any other feature which helps to identify the CEBs.

Table 2 — Examples of designation

Designation	Description	Example
CEB01D	Ordinary compressed earth block used as an element in a non load bearing structure in a dry environment not subject to mechanical abrasion	Internal partition of a single family ground floor house
CEBFF3RA	Fine facing compressed earth block used as an element in a load-bearing structure exposed to rain weathering by lateral spraying as well as to mechanical abrasion	External wall of a 3-storey building of high quality appearance exposed to driving rain and to sand storms

**ARS 672: 1996 - Compressed earth blocks
Standard for definition, classification and designa-
tion of earth mortars**

1 General

1.1 Object

The aim of the present standard is to define earth mortars (EMs), to classify them according to their appearance, their conditions of use, and to determine the categories into which they fall as well as their designations.

1.2 Fields of application

The definitions, classifications and designations of the present standard are applicable in drawing up all technical, administrative and contractual documents relating to compressed earth block technology, and relate both to public and to private contracts.

The standard applies exclusively to EMs intended for the realisation of simple built structures in common masonry with thick mortar joints (walls, partitions, piers, small lintels, arches, vaults, domes, etc.) and of any similar built structure.

The standard applies only to mortars prepared on site and intended to be used on the spot.

The standard does not apply to EMs used for flooring or tiling, nor does it apply to reinforced masonry.

The standard is not applicable in areas subject to earthquakes, floods or cyclones to an extent that requires the application of appropriate rules in order to avoid major damage.

2 Definition of EMs

An earth mortar (EM) is a mortar used for compressed earth block masonry of a traditional type using thick mortar joints.

An earth mortar consists principally of raw earth and water and owes its cohesion in a humid or a dry state essentially to the clay fraction of the earth; an additive and/or filler can, however, be added to the earth to improve or enhance particular characteristics of the mortar.

3 Classification of EMs

3.1 Classification according to use

EMs can be classified into two groups according to use:

- ordinary EMs;
- facing EMs.

3.1.1 Ordinary EMs (EM O)

These are EMs used in masonry structures intended to be covered by some form of protection.

3.1.2 Facing EMs (EM F)

These are EMs used in masonry structures intended to remain visible. One can differentiate between:

- normal facing EMs (EM NF);
- fine facing EMs (EM FF).

The difference between these two facing EMs is restricted to their appearance without affecting their other characteristics.

3.2 Classification according to field of use

The fields of use of EMs within masonry structures are classified according to two types of constraint which can occur simultaneously:

- mechanical constraints;
- environmental constraints.

3.2.1 Mechanical constraints

These are defined according to three categories of resistance:

- *category 1*: structural elements which are not load-bearing and structural elements capable of withstanding limited external (live) loads (e.g. fill-in in a load-bearing structure) (e.g. boundary wall) (e.g. a single-storey building made of load-bearing structural elements);
- *category 2*: structural elements capable of withstanding important external (live) loads (e.g. a two storey building with accessible terrace made of thin load-bearing structural elements);
- *category 3*: structural elements capable of withstanding high external (live) loads (e.g. a three storey public building made of thin load-bearing structural elements).

3.2.2 Environmental constraints

These are defined by 4 categories of environment:

- *category D*: structural elements located in a dry environment with no danger of being wet (e.g. internal partitions) (e.g. external walls which are not exposed or which are protected from water damage);
- *category R*: structural elements capable of withstanding water damage by lateral spraying (e.g. lateral walls exposed to rain) (e.g. bathroom walls being splashed);

- *category C*: structural elements capable of withstanding water damage by vertical penetration (capillary rise, penetration by gravity, suction or internal condensation)
(e.g. external walls unprotected from capillary rise)
(e.g. internal walls unprotected from water leaking through the roof);
- *category A*: structural elements capable of withstanding mechanical abrasion (impact, rubbing or wind damage)
(e.g. corners or walls subject to impact)
(e.g. areas subject to rubbing by animals)
(e.g. areas subject to sand storms).

4 Designation of EMs

The designation of earth mortars includes the following indications, to be given in the same order:

- product designation
EM for «earth mortar»;
- designation according to use:
O for «ordinary»
F for «facing»
NF for «normal facing»
FF for «fine facing»;
- designation according to mechanical constraints
1 for «category 1»
2 for «category 2»
3 for «category 3»;
- designation according to the constraints of the hygrometric environment
D for «category D»
R for «category R»
C for «category C»;
- designation according to the constraints of the mechanical abrasion environment:
A for «category A».

The EM designation may also include the following indications to be given in the same order:

- colour;
- any other feature which helps to identify EMs.

Table 1 — Examples of designation

Designation	Description	Example
EM O 1 D	Ordinary earth mortar used as an element in a non load bearing structure in a dry environment not subject to mechanical abrasion	Internal partition of a single family ground floor house
EM FF3 RA	Fine facing earth mortar used as an element in a load-bearing structure exposed to rain weathering by lateral spraying as well as to mechanical abrasion	External wall of a 3-storey building of high quality appearance exposed to driving rain and to sand storms

ARS 673: 1996 - Compressed earth blocks Standard for definition, classification and designa- tion of compressed earth block masonry

1 General

1.1 Object

The aim of the present standard is to define various forms of compressed earth block masonry (CEBM), to classify them according to their appearance, their conditions of use, and to determine the categories into which they fall as well as their designations.

1.2 Fields of application

The definitions, classifications and designations of the present standard are applicable in drawing up all technical, administrative and contractual documents relating to compressed earth block technology, and relate both to public and to private contracts.

The standard applies exclusively to forms of CEBM intended for the realisation of simple built structures in common masonry with thick mortar joints (walls, partitions, piers, small lintels, arches, vaults, domes, etc.) and of any similar built structure.

The standard does not apply to reinforced CEBM.

The standard is not applicable in areas subject to earthquakes, floods or cyclones to an extent that requires the application of appropriate rules in order to avoid major damage.

2 Definition of CEBM

Compressed earth block masonry is masonry of a traditional type using thick earth mortar joints.

3 Classification of CEBM

3.1 Classification according to use

CEBMs can be classified into two groups according to use:

- ordinary CEBMs;
- facing CEBMs.

3.1.1 Ordinary CEBM (CEBM O)

These are CEBMs used in structures intended to be covered by some form of protection. They are assembled using ordinary CEBs and ordinary EMs.

3.1.2 Facing CEBM (CEBM F)

These are CEBMs used in structures intended to remain visible. They are assembled using facing CEBs and facing EMs. One can differentiate between:

- normal facing CEBMs (CEBM NF) assembled using CEB NF and EM NF;
- fine facing CEBMs (CEBM FF) assembled using CEB FF and EM FF.

The difference between these two facing CEBMs is restricted to their appearance without affecting their other characteristics.

3.2 Classification according to field of use

The fields of use of CEBMs within masonry structures are classified according to two types of constraint which can occur simultaneously:

- mechanical constraints;
- environmental constraints.

3.2.1 Mechanical constraints

These are defined according to three categories of resistance:

- *category 1*: structural elements which are not load-bearing and structural elements capable of withstanding limited external (live) loads (e.g. fill-in in a load-bearing structure) (e.g. boundary wall) (e.g. a single-storey building made of load-bearing structural elements);
- *category 2*: structural elements capable of withstanding important external (live) loads (e.g. a two storey building with accessible terrace made of thin load-bearing structural elements);
- *category 3*: structural elements capable of withstanding high external (live) loads (e.g. a three storey public building made of thin load-bearing structural elements).

3.2.2 Environmental constraints

These are defined by 4 categories of environment:

- *category D*: structural elements located in a dry environment with no danger of being wet (e.g. internal partitions) (e.g. external walls which are not exposed or which are protected from water damage);
- *category R*: structural elements capable of withstanding water damage by lateral spraying (e.g. lateral walls exposed to rain) (e.g. bathroom walls being splashed);
- *category C*: structural elements capable of withstanding water damage by vertical penetration (capillary rise, penetration by gravity, suction or internal condensation) (e.g. external walls unprotected from capillary rise) (e.g. internal walls unprotected from water leaking through the roof);
- *category A*: structural elements capable of withstanding mechanical abrasion (impact, rubbing or wind damage) (e.g. corners or walls subject to impact) (e.g. areas subject to rubbing by animals) (e.g. areas subject to sand storms).

4 Designation of forms of CEBM

The designation of forms of compressed earth block masonry includes the following indications, to be given in the same order:

- product designation:
CEBM for «compressed earth block masonry»;
- designation according to use:
O for «ordinary»
F for «facing»
NF for «normal facing»
FF for «fine facing»;
- designation according to mechanical constraints:
1 for «category 1»
2 for «category 2»
3 for «category 3»;
- designation according to the constraints of the hygrometric environment:
D for «category D»
R for «category R»
C for «category C»;
- designation according to the constraints of the mechanical abrasion environment:
A for «category A».

The CEBM designation may also include the following indications to be given in the same order:

- type: load bearing or non load bearing;
- colour;
- decorative effects;
- any other feature which helps to identify CEBMs.

Table 1 — Examples of designation

Designation	Description	Example
CEBM O 1 D	Ordinary compressed earth block masonry used as a component of a non load bearing structure in a dry environment not subject to mechanical abrasion	Internal partition of a single family ground floor house
CEBM FF 3 RA	Facing compressed earth block masonry used as a component in a load-bearing structure exposed to rain weathering by lateral sprinkling as well as to mechanical abrasion	External wall of a 3-storey building of high quality appearance exposed to driving rain and to sand storms

COMPONENTS AND ELEMENTS STANDARDS

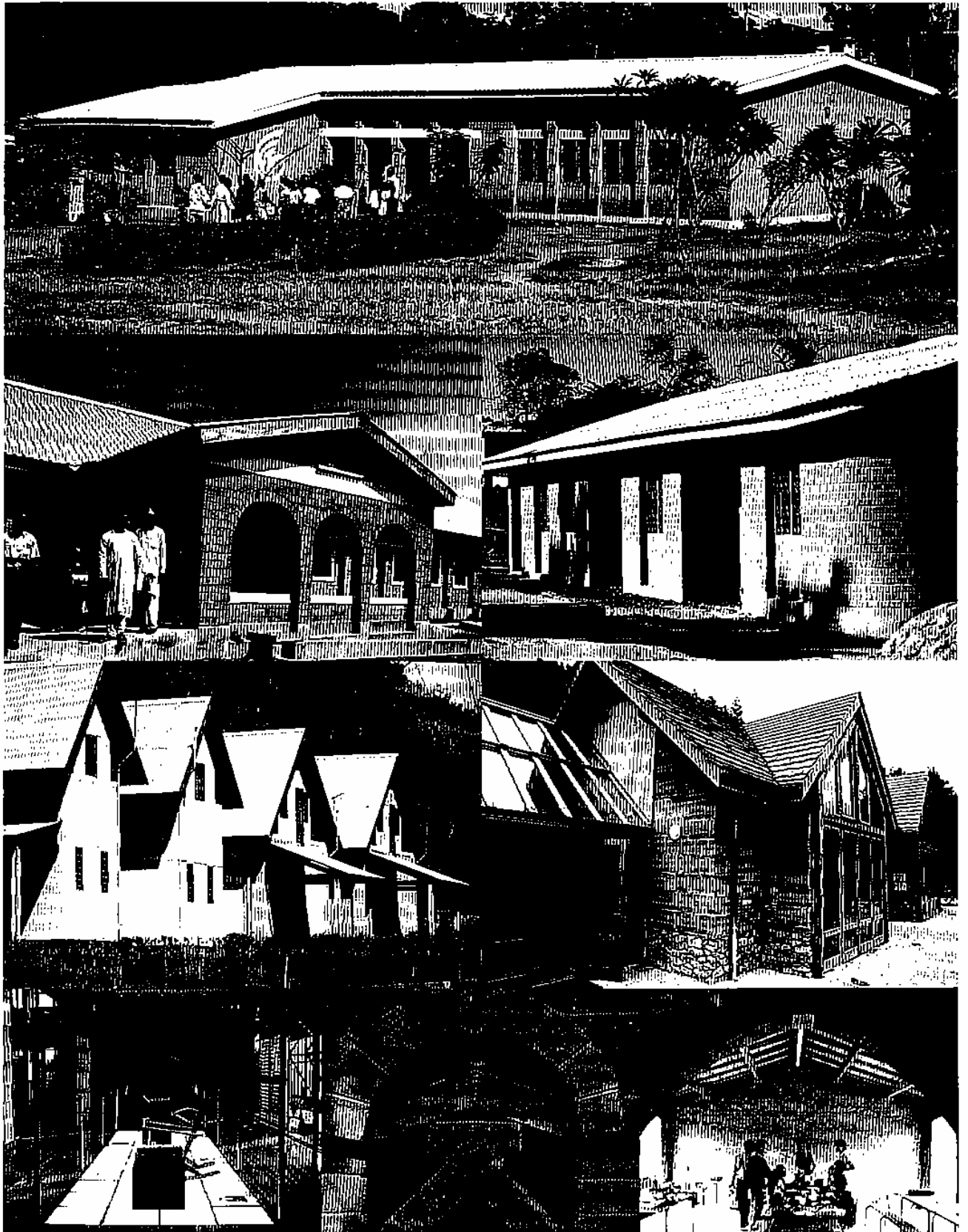

In order to open up the range of possible uses of compressed earth blocks as widely as possible in very different contexts, the technical specifications have been adapted to the specific demands which will be made on the blocks, the mortars and the masonry systems.

This gives a highly flexible system, enabling all eventualities to be covered, whilst respecting the spirit of a quality-based approach, i.e. giving a perfect match between the demands on the one hand and the performances on the other, with no wasting of resources.

ARS 674: 1996 - Compressed earth blocks

Technical specifications for ordinary compressed earth blocks

1 General

1.1 Object

The aim of the present standard is to define the requirements applicable to ordinary compressed earth blocks (CEB O).

1.2 Field of application

The field of application is that defined by the standard «ARS 671: 1996 - Compressed earth blocks - Definition, classification and designation of compressed earth blocks».

1.3 Definition

The definition of ordinary compressed earth blocks is specified by the standard «ARS 671: 1996 - Compressed earth blocks - Definition, classification and designation of compressed earth blocks».

1.4 Classification

The classification of ordinary compressed earth blocks is specified by the standard «ARS 671: 1996 - Compressed earth blocks - Definition, classification and designation of compressed earth blocks».

1.5 Designation

The designation of ordinary compressed earth blocks is specified by the standard «ARS 671: 1996 - Compressed earth blocks - Definition, classification and designation of compressed earth blocks».

1.6 Reference

Standard «ARS 671: 1996 - Compressed earth blocks - Definition, classification and designation of compressed earth blocks».

2 Specifications

2.1 Textural characteristics

The earth should not contain any particles with a diameter greater than 20 mm. To obtain an optimal result, the diameter of the largest particles will be restricted to 5 mm.

2.2 Dimensional characteristics

2.2.1 Dimensions

The most commonly employed full compressed earth blocks have the following theoretical moulding dimensions and nominal dimensions:

- length: 29.50 cm;
- width: 14.00 cm;
- height: 9.00 cm to 9.50 cm.

These blocks are used as a reference here for the terms of the specifications which follow. For CEBs of different dimensions, tolerances should be adjusted using a linear mathematical relationship.

The measurements given are the net block dimensions, not counting any hollows or indentations.

Special blocks can be developed using other main formats.

Dimensional tolerances are as follows:

- length: + 2 to - 3 mm;
- width: + 2 to - 3 mm;
- height: + 3 to - 3 mm.

In addition, the difference between the corresponding dimension of two CEBs of any kind from the same supply must not exceed 4 mm for the length, 3 mm for the width and 5 mm for the height.

2.2.2 Thickness of sides of indented or hollow blocks

For all faces: minimum 25 mm or 3 times the diameter of the largest particle if the diameter of the largest particle exceeds 8 mm.

2.3 Geometric characteristics

2.3.1 Irregular geometry

CEBs which have a deliberately irregular geometrical form are not subject to the specifications of this article. However, the flatness of the bed faces must meet the conditions which follow.

2.3.2 Parallelism

Defects of parallelism or of right angles, and also the acceptable sweep of a face, cannot exceed the tolerance for the dimension affected.

2.3.3 Surface smoothness

- Sides: the sweep must not exceed 2 mm.
- Compression surfaces: the sweep must not exceed 3 mm.

2.3.4 Edge smoothness

- The sweep must not exceed 3 mm.
- Some roughness on the edges can be tolerated, whether it is due to demoulding or caused by mishandling.

2.3.5 Surface obliquity

- For exterior faces, form and dimensional tolerances must be respected.

- Interior faces and the hollows of hollow or indented blocks must be oblique and must have no sharp corners.

2.4 Appearance characteristics

2.4.1 Damage

A distinction is made between mechanical damage caused by impact when handling CEBs and cracks or other defects which result from an imperfect production process.

For cracks and other manufacturing defects, the prescriptions which follow are applicable.

For mechanical damage, the following rule is to be respected: damage which has no effect on the appearance of the masonry (such as chips on the side of the CEB which is not visible) will not be taken into account.

The following are regarded as damaged:

- any broken CEB;
- any CEB displaying chipped edges or corners the overall volume of which exceed 5% of the volume of the CEB.

2.4.2 General appearance

The CEBs should display no systematic defects such as cracks or significant chips of a kind likely to jeopardise correct execution and the stability of the masonry.

2.4.3 Holes, punctures and scratches

For exposed faces, these must affect no more than 20% of the surface and not exceed 5 mm in depth.

2.4.4 Roughness

The exposed faces can have a grainy and rough appearance.

2.4.5 Chipped corners

Chipped corners and edges which do not extend over more than 10 mm and which do not exceed 10 mm in depth are tolerated on all surfaces.

2.4.6 Flaking, splitting

These are tolerated provided mechanical performance is not affected.

2.4.7 Cracks, crazing, fissures

Micro-cracks:

- are tolerated on all faces.

Macro-cracks:

Conditions of acceptability for all faces:

- they must not exceed 1 mm in width;
- they must not exceed 40 mm in length;
- they must not exceed 10 mm in depth;
- they must not exceed 3 in number on any one surface.

2.5 Physicochemical characteristics

2.5.1 Pitting

No pitting due to the bursting of expansive materials is tolerated.

2.5.2 Efflorescence

CEBs must not display any significant and lasting efflorescence covering more than 1/3 of the total surface of the CEBs. A faint whitish film or a thin band are not taken into account.

2.6 Mechanical, hygrometric and physical characteristics

Mechanical, hygrometric and physical characteristics are determined by the values shown in the following table.

Table 1 — Mechanical, hygrometric and physical characteristics required for ordinary CEBs

Designation	Environmental constraint category	Mechanical constraint category	f_b dry N/mm ²	f_b wet N/mm ²	Water absorption %	Abrasion Loss of matter %
CEB O 1 D	Dry environment (D)	1	≥ 2	N/A	N/A	N/A
CEB O 2 D		2	≥ 4	N/A	N/A	N/A
CEB O 3 D		3	≥ 6	N/A	N/A	N/A
CEB O 1 R	Effect of water by lateral spraying (R)	1	≥ 2	≥ 1	N/A	N/A
CEB O 2 R		2	≥ 4	≥ 2	N/A	N/A
CEB O 3 R		3	≥ 6	≥ 3	N/A	N/A
CEB O 1 C	Effect of water by vertical penetration (C)	1	≥ 2	≥ 1	≤ 15	N/A
CEB O 2 C		2	≥ 4	≥ 2	≤ 10	N/A
CEB O 3 C		3	≥ 6	≥ 3	≤ 5	N/A

- Note:
- 1) N/A = not applicable
 - 2) The use of CEBs in R and C category environments requires using a stabiliser if the protection provided is not guaranteed. If the protection provided against water damage is guaranteed, the environment is regarded as category D.
 - 3) If tests to establish water absorption or abrasion are not feasible, or if the results are not available, this deficiency can be compensated by increasing the requirements for the dry and/or wet compressive strength by one category.
 - 4) The values given are the average values obtained from tests carried out on a set of samples.

ARS 675: 1996 - Compressed earth blocks

Technical specifications for facing compressed earth blocks

1 General

1.1 Object

The aim of the present standard is to define the requirements applicable to facing compressed earth blocks (CEB F).

1.2 Field of application

The field of application is that defined by the standard «ARS 671: 1996 - Compressed earth blocks - Definition, classification and designation of compressed earth blocks».

1.3 Definition

The definition of facing compressed earth blocks is specified by the standard «ARS 671: 1996 - Compressed earth blocks - Standard for definition, classification and designation of compressed earth blocks».

1.4 Classification

The classification of facing compressed earth blocks is specified by the standard «ARS 671: 1996 - Compressed earth blocks - Definition, classification and designation of compressed earth blocks».

1.5 Designation

The designation of facing compressed earth blocks is specified by the standard «ARS 671: 1996 - Compressed earth blocks - Standard for definition, classification and designation of compressed earth blocks».

1.6 Reference

Standard «ARS 671: 1996 - Compressed earth blocks - Standard for definition, classification and designation of compressed earth blocks».

2 Specifications

2.1 Textural characteristics

The earth should preferably not contain any particles with a diameter greater than 10 mm. To obtain an optimal result, the diameter of the largest particles will be restricted to 5 mm.

2.2 Dimensional characteristics

2.2.1 Dimensions

The most commonly employed full compressed earth blocks have the following theoretical moulding dimensions and nominal dimensions:

- length: 29.50 cm;
- width: 14.00 cm;
- height: 9.00 cm to 9.50 cm.

These blocks are used as a reference here for the terms of the specifications which follow. For CEBs of different dimensions, tolerances should be adjusted using a linear mathematical relationship.

The measurements given are the net block dimensions, not counting any hollows or indentations.

Special blocks can be developed using other main formats.

Dimensional tolerances are as follows:

- length: + 1 to - 3 mm;
- width: + 1 to - 2 mm;
- height: + 2 to - 2 mm.

In addition, the difference between the corresponding dimension of two CEBs of any kind from the same supply must not exceed 3 mm for the length, 2 mm for the width and 3 mm for the height.

2.2.2 Thickness of sides of indented or hollow blocks

For all faces: minimum 25 mm or 3 times the diameter of the largest particle if the diameter of the largest particle exceeds 8 mm.

2.3 Geometric characteristics

2.3.1 Irregular geometry

CEBs which have a deliberately irregular geometrical form are not subject to the specifications of this article. However, the flatness of the bed faces must meet the conditions which follow.

2.3.2 Parallelism

Defects of parallelism or of right angles, and also the acceptable sweep of a face, cannot exceed half the tolerance for the dimension affected.

2.3.3 Surface smoothness

- Sides: the sweep must not exceed 1 mm.
- Compression surfaces: the sweep must not exceed 3 mm.

2.3.4 Edge smoothness

- The sweep must not exceed 2 mm.
- Some roughness on the edges can be tolerated, provided this is due to demoulding and not caused by mishandling.

2.3.5 Surface obliquity

- For exterior faces, form and dimensional tolerances must be respected.
- Interior faces and the hollows of hollow or indented blocks must be oblique and must have no sharp corners.

2.4 Appearance characteristics

These characteristics are common to both NF and FF blocks except where specific indications are given.

2.4.1 Damage

A distinction is made between mechanical damage caused by impact when handling CEBs and cracks or other defects which result from an imperfect production process.

For cracks and other manufacturing defects, the prescriptions which follow are applicable.

For mechanical damage, the following rule is to be respected: damage which has no effect on the appearance of the masonry (such as chips on the side of the CEB which is not visible) will not be taken into account.

The following are regarded as damaged:

- any broken CEB;
- any CEB displaying chipped edges or corners the overall volume of which exceed 2% of the volume of the CEB.

2.4.2 General appearance

The CEBs should display no systematic defects such as cracks or significant chips of a kind likely to jeopardise correct execution and the stability of the masonry.

90% of facing compressed earth blocks should not display on the faces intended to remain visible, any cracks, chips or efflorescence compromising the appearance of the built structure required, visible at a distance of two metres.

2.4.3 Holes, punctures and scratches

For exposed faces in the NF category, these must affect no more than 10% of the surface and not exceed 2 mm in depth.

For exposed faces in the FF category, these must affect no more than 2.5% of the surface and not exceed 1 mm in depth.

2.4.4 Roughness

The exposed faces can be rough for the NF category, must be smooth for the FF category, other than when a particular effect is being sought by the client.

2.4.5 Chipped corners

Chipped corners and edges which do not extend over more than 10 mm and which do not exceed 10 mm in depth are tolerated on all surfaces.

2.4.6 Flaking, splitting

These are not tolerated on any surface.

2.4.7 Cracks

Micro-cracks:

- can be tolerated on all faces.

Macro-cracks:

Conditions of acceptability for all faces:

- they must not exceed 0.5 mm in width;
- they must not exceed 20 mm in length;
- they must not exceed 5 mm in depth;
- they must not exceed 2 in number for NF category CEBs, 1 in number for FF category CEBs, on any one surface.

2.4.8 Colour

This can be:

- uniform colour*: all the facing CEBs of the lot have the same basic colour on all visible faces.
- varied colour*: facing CEBs from the same lot have different shades of colour as defined by the client.

2.4.9 Structure

CEBs must have a uniform and homogeneous structure.

Depending on the structure, the following main indications of the surface of materials can be distinguished:

- smooth*: a closed structure surface for which the voids between grains have been completely filled; any hollows are superficial and spread evenly over the surface.
- granulated*: a surface with a practically closed surface, characterised by the calibre of the grains and by the voids spread evenly between these particles.

2.4.10 Surface texture

The surface of CEBs has a homogeneous texture. The following indications of the surface texture depending on their particular treatment, mechanical or not, can be distinguished: flat, split, grooved, streaked, etc. This list is not restrictive.

2.5 Physicochemical characteristics

2.5.1 Pitting

No pilling due to the bursting of expansive materials is tolerated.

2.5.2 Efflorescence

CEBs must not display any significant and lasting efflorescence covering more than 1/4 of the total surface of the CEBs. A faint whitish film or a thin band are not taken into account.

2.6 Mechanical, hygrometric and physical characteristics

Mechanical, hygrometric and physical characteristics are determined by the values shown in the following table.

Table 1 — Mechanical, hygrometric and physical characteristics required for facing CEBs

Designation	Environmental constraint category	Mechanical constraint category	f_b dry N/mm ²	f_b wet N/mm ²	Water absorption %	Abrasion Loss of matter %
CEBNF1D or CEBFF1D	Dry environment (D)	1	≥ 2	N/A	N/A	≤ 10
CEBNF2D or CEBFF2D		2	≥ 4	N/A	N/A	≤ 5
CEBNF3D or CEBFF3D		3	≥ 6	N/A	N/A	≤ 2
CEBNF1R or CEBFF1R	Effect of water by lateral spraying (R)	1	≥ 2	≥ 1	N/A	≤ 10
CEBNF2R or CEBFF2R		2	≥ 4	≥ 2	N/A	≤ 5
CEBNF3R or CEBFF3R		3	≥ 6	≥ 3	N/A	≤ 2
CEBNF1C or CEBFF1C	Effect of water by vertical penetration (C)	1	≥ 2	≥ 1	≤ 15	≤ 10
CEBNF2C or CEBFF2C		2	≥ 4	≥ 2	≤ 10	≤ 5
CEBNF3C or CEBFF3C		3	≥ 6	≥ 3	≤ 5	≤ 2

- Note:
- 1) N/A = not applicable
 - 2) The use of CEBs in R and C category environments requires using a stabiliser if the protection provided is not guaranteed. If the protection provided against water damage is guaranteed, the environment is regarded as category D.
 - 3) If tests to establish water absorption or abrasion are not feasible, or if the results are not available, this deficiency can be compensated by increasing the requirements for the dry and/or wet compressive strength by one category.
 - 4) The values given are the average values obtained from tests carried out on a set of samples.

ARS 676: 1996 - Compressed earth blocks

Technical specifications for ordinary earth mortars

1 General

1.1 Object

The aim of the present standard is to define the requirements applicable to ordinary earth mortars (EM O).

1.2 Field of application

The field of application is that defined by the standard «ARS 672: 1996 - Compressed earth blocks - Standard for definition, classification and designation of earth mortars».

1.3 Definition

The definition of ordinary earth mortars is specified by the standard «ARS 672: 1996 - Compressed earth blocks - Standard for definition, classification and designation of earth mortars».

1.4 Classification

The classification of ordinary earth mortars is specified by the standard «ARS 672: 1996 - Compressed earth blocks - Standard for definition, classification and designation of earth mortars».

1.5 Designation

The designation of ordinary earth mortars is specified by the standard «ARS 672: 1996 - Compressed earth blocks - Standard for definition, classification and designation of earth mortars».

1.6 Reference

Standard «ARS 672: 1996 - Compressed earth blocks - Standard for definition, classification and designation of earth mortars».

2 Specifications

2.1 General characteristics

The characteristics of ordinary mortars must be compatible with the category of blocks chosen.

2.2 Textural characteristics

The earth must contain at least 90% of grains the dimensions of which are less than 1/3 of the thickness of the joint. 10% of grains with a maximum dimension of between 1/3 and 1/2 of the thickness of the joint is tolerated. The use of an earth mortar the largest grain size of which is less than or equal to 4 mm is recommended.

2.3 Appearance characteristics

2.3.1 General appearance

Ordinary EMs should display no systematic defects such as cracks or significant chips of a kind likely to jeopardise correct execution and the stability of the masonry.

2.3.2 Cracks

Micro-cracks and macro-cracks can be tolerated on all surfaces but their presence must not be concentrated or systematic over a part or the whole of the built structure.

2.4 Physicochemical characteristics

2.4.1 Pitting

No pitting due to the bursting of expansive materials is tolerated.

2.4.2 Efflorescence

Ordinary EMs must not display any significant and lasting efflorescence covering a large area of the EM. A faint whitish film or a thin band are not taken into account.

2.5 Mechanical, hygrometric and physical characteristics

Table 1 — Mechanical, hygrometric and physical characteristics of ordinary earth mortars

Designation	Environmental constraint category	Mechanical constraint category	f_b dry N/mm ²	f_b wet N/mm ²	Water absorption %	Abrasion Loss of matter %
EMO1D	Dry environment (D)	1	≥ 0,5	N/A	N/A	N/A
EMO2D		2	≥ 1,5	N/A	N/A	N/A
EMO3D		3	≥ 2,5	N/A	N/A	N/A
EMO1R	Effect of water by lateral spraying (R)	1	≥ 0,5	≥ 0,5	≤ 30	N/A
EMO2R		2	≥ 1,5	≥ 1	≤ 20	N/A
EMO3R		3	≥ 2,5	≥ 1,5	≤ 10	N/A
EMO1C	Effect of water by vertical penetration (C)	1	≥ 0,5	≥ 0,5	≤ 30	N/A
EMO2C		2	≥ 1,5	≥ 1	≤ 20	N/A
EMO3C		3	≥ 2,5	≥ 1,5	≤ 10	N/A

- Note:
- 1) N/A = not applicable
 - 2) The use of EMs in R and C category environments requires using a stabiliser if the protection provided is not guaranteed. If the protection provided against water damage is guaranteed, the environment is regarded as category D.
 - 3) If tests to establish water absorption or abrasion are not feasible, or if the results are not available, this deficiency can be compensated by increasing the requirements for the dry and/or wet compressive strength by one category.
 - 4) The values given are the average values obtained from tests carried out on a set of samples.

ARS 677: 1996 - Compressed earth blocks Technical specifications for facing earth mortars

1 General

1.1 Object

The aim of the present standard is to define the requirements applicable to facing earth mortars (EM F).

1.2 Field of application

The field of application is that defined by the standard «ARS 672: 1996 - Compressed earth blocks - Standard for definition, classification and designation of earth mortars».

1.3 Definition

The definition of facing earth mortars is specified by the standard «ARS 672: 1996 - Compressed earth blocks - Standard for definition, classification and designation of earth mortars».

1.4 Classification

The classification of facing earth mortars is specified by the standard «ARS 672: 1996 - Compressed earth blocks - Standard for definition, classification and designation of earth mortars».

1.5 Designation

The designation of facing earth mortars is specified by the standard «ARS 672: 1996 - Compressed earth blocks - Standard for definition, classification and designation of earth mortars».

1.6 Reference

Standard «ARS 672: 1996 - Compressed earth blocks - Standard for definition, classification and designation of earth mortars».

2 Specifications

2.1 General characteristics

The characteristics of facing mortars must be compatible with the category of blocks chosen.

2.2 Textural characteristics

The earth should not contain grains larger than $\frac{1}{3}$ of the thickness of the joints. The use of an earth mortar the largest grain size of which is less than or equal to 4 mm is recommended.

2.3 Appearance characteristics

2.3.1 General appearance

Facing EMs should display no systematic defects such as cracks or significant chips of a kind likely to jeopardise correct execution and the stability of the masonry.

2.3.2 Cracks

Micro-cracks:

- can be tolerated on all exposed faces.

Macro-cracks:

Conditions of acceptability for all faces:

- they must not exceed 0.5 mm in width;
- they must not exceed 20 mm in length;
- they must not exceed 10 mm in depth;
- the presence of acceptable macro-cracks must not be concentrated or found throughout one part or the whole of the built structure.

2.3.3 Colour

The colour of facing EMs should be uniform throughout the built structure. It may differ from that of the CEBs.

2.4 Physical-chemical characteristics

2.4.1 Pitting

No pitting due to the bursting of expansive materials is tolerated.

2.4.2 Efflorescence

Facing EMs must not display any significant and lasting efflorescence covering a large area of the EM. A faint whitish film or a thin band are not taken into account.

2.5 Mechanical, hygrometric and physical characteristics

Table 1 — Mechanical, hygrometric and physical characteristics of facing earth mortars

Designation	Environmental constraint category	Mechanical constraint category	f_b dry N/mm ²	f_b wet N/mm ²	Water absorption %	Abrasion Loss of matter %
EM NF 1 D or EM FF 1 D	Dry environment (D)	1	≥ 0,5	N/A	N/A	≤ 15
EM NF 2 D or EM FF 2 D		2	≥ 1,5	N/A	N/A	≤ 10
EM NF 3 D or EM FF 3 D		3	≥ 2,5	N/A	N/A	≤ 5
EM NF 1 R or EM FF 1 R	Effect of water by lateral spraying (R)	1	≥ 0,5	≥ 0,5	≤ 30	≤ 15
EM NF 2 R or EM FF 2 R		2	≥ 1,5	≥ 1	≤ 20	≤ 10
EM NF 3 R or EM FF 3 R		3	≥ 2,5	≥ 1,5	≤ 10	≤ 5
EM NF 1 C or EM FF 1 C	Effect of water by vertical penetration (C)	1	≥ 0,5	≥ 0,5	≤ 30	≤ 15
EM NF 2 C or EM FF 2 C		2	≥ 1,5	≥ 1	≤ 20	≤ 10
EM NF 3 C or EM FF 3 C		3	≥ 2,5	≥ 1,5	≤ 10	≤ 5

- Note:
- 1) N/A = not applicable
 - 2) The use of EMs in R and C category environments requires using a stabiliser if the protection provided is not guaranteed. If the protection provided against water damage is guaranteed, the environment is regarded as category D.
 - 3) If tests to establish water absorption or abrasion are not feasible, or if the results are not available, this deficiency can be compensated by increasing the requirements for the dry and/or wet compressive strength by one category.
 - 4) The values given are the average values obtained from tests carried out on a set of samples.

ARS 678: 1996 - Compressed earth blocks Technical specifications for ordinary compressed earth block masonry

1 General

1.1 Object

The aim of the present standard is to define the requirements applicable to ordinary compressed earth block masonry (CEBM O) intended to be covered.

The covering can be a wash, a fine or a thick render or another kind of protection or decoration. It is generally intended to protect against the effects of water or mechanical abrasion, but could also have an aesthetic role.

1.2 Field of application

The field of application is that defined by the standard «ARS 673: 1996 - Compressed earth blocks - Standard for definition, classification and designation of compressed earth block masonry».

1.3 Definition

The definition of compressed earth block masonry is specified by the standard «ARS 673: 1996 - Compressed earth blocks - Standard for definition, classification and designation of compressed earth block masonry».

1.4 Classification

The classification of ordinary compressed earth block masonry is specified by the standard «ARS 673: 1996 - Compressed earth blocks - Standard for definition, classification and designation of compressed earth block masonry».

1.5 Designation

The designation of ordinary compressed earth block masonry is specified by the standard «ARS 673: 1996 - Compressed earth blocks - Standard for definition, classification and designation of compressed earth block masonry».

1.6 Reference

Standard «ARS 673: 1996 - Compressed earth blocks - Standard for definition, classification and designation of compressed earth block masonry».

2 Specifications

2.1 Configuration characteristics

Bonding patterns will be those used for traditional masonry using small masonry elements.

The vertical and horizontal joints should be perfectly executed to ensure the best adhesion possible between blocks and mortar thus ensuring the optimal transmission of loads.

In order to avoid superimposed vertical joints, the overlap between CEBs must be at least 1/4 of their length.

2.2 Dimensional characteristics

The vertical and horizontal joints should be minimum 8 mm and maximum 15 mm in thickness. Locally, a thickness of 20 mm can be tolerated.

Load bearing masonry will have a minimum thickness of 14 cm with a maximum slenderness ratio of 20. Non load bearing masonry will have a minimum thickness of 9 cm.

2.3 Geometric characteristics

The position of the vertical and horizontal joints must be consistent with the brickwork drawings which are provided before building work begins.

The acceptable sweep of any surface cannot exceed 10 mm along any vertical or horizontal length. Deviation from verticality cannot exceed 7 mm per storey.

Tolerance along the length of the masonry elements is as follows:

For thin walls (<20 cm thick):

- for small size sections of masonry (<100 cm), the tolerance is 10 mm;
- for larger size sections of masonry (>100 cm), the tolerance is 25 mm.

For thick walls (>20 cm thick):

- for small size sections of masonry (<100 cm), the tolerance is 15 mm;
- for larger size sections of masonry (>100 cm), the tolerance is 30 mm.

2.4 Physical-chemical characteristics

2.4.1 Efflorescence

The masonry must not display any significant and lasting efflorescence covering a large area of the surface. A faint whitish film or a thin band are not taken into account.

2.5 Mechanical, hygrometric and physical characteristics

The mechanical, hygrometric and physical characteristics of the masonry are not only a function of the quality of its component products (compressed earth blocks and earth mortars), but are also highly dependent on the quality of the workmanship and curing conditions.

2.5.1 Dry characteristic compressive strength of the CEBM wall

The dry characteristic compressive strength (f_k) of the CEBM wall must be at least equal to the dry characteristic compressive stress at the foot of the wall, determined by a static calculation of the vertical load on the masonry, in accordance with the standards in force.

2.5.2 Compressive strength of the CEBs

For CEBMs in a dry or protected environment, the CEBs must have a dry compressive strength (f_b dry) at least equal to 10 times the value of the dry characteristic compressive strength (f_k) required for the wall.

For CEBMs in a wet environment, with no protection against water damage, the CEBs should have a wet compressive strength (f_b wet) at least equal to 10 times the value of the dry characteristic compressive strength (f_k) required for the wall.

The value of the compressive strength of the CEBs fixed in this way will determine the category of resistance of the CEBs to mechanical constraints.

2.5.3 Thermal resistance

The thermal resistance of masonry under internal or external climatic conditions is specified only in the case of masonry expressly designed to provide thermal insulation.

2.5.4 Thermal capacity

Thermal capacity per unit of volume is specified only in the case of masonry specifically intended to provide thermal capacity. Thermal capacity is determined in the light of the project requirements.

2.5.5 Acoustic attenuation coefficient

The acoustic attenuation coefficient is specified only in the case of masonry expressly designed to provide acoustic insulation.

2.5.6 Fire resistance

The fire resistance of masonry is specified only in the case of masonry expressly designed to resist fire.

ARS 679: 1996 - Compressed earth blocks

Technical specifications for facing compressed earth block masonry

1 General

1.1 Object

The aim of the present standard is to define the requirements applicable to facing compressed earth block masonry (CEBM F) intended to remain visible.

1.2 Field of application

The field of application is that defined by the standard «ARS 673: 1996 - Compressed earth blocks - Standard for definition, classification and designation of compressed earth block masonry».

1.3 Definition

The definition of facing compressed earth block masonry is specified by the standard «ARS 673: 1996 - Compressed earth blocks - Standard for definition, classification and designation of compressed earth block masonry».

1.4 Classification

The classification of facing compressed earth block masonry is specified by the standard «ARS 673: 1996 - Compressed earth blocks - Standard for definition, classification and designation of compressed earth block masonry».

1.5 Designation

The designation of facing compressed earth block masonry is specified by the standard «ARS 673: 1996 - Compressed earth blocks - Standard for definition, classification and designation of compressed earth block masonry».

1.6 Reference

Standard «ARS 673: 1996 - Compressed earth blocks - Standard for definition, classification and designation of compressed earth block masonry».

2 Specifications

2.1 Configuration characteristics

Bonding patterns will be those used for traditional masonry using small masonry elements.

The vertical and horizontal joints should be perfectly executed to ensure the best adhesion possible between blocks and mortar thus ensuring the optimal transmission of loads.

In order to avoid superimposed vertical joints, the overlap between CEBs must be at least 1/4 of their length.

2.2 Dimensional characteristics

The vertical and horizontal joints should be minimum 8 mm and maximum 15 mm in thickness.

Load bearing masonry will have a minimum thickness of 14 cm with a maximum slenderness ratio of 20. Non load bearing masonry will have a minimum thickness of 9 cm.

Walls less than 20 cm thick will have an expansion joint every 5 m maximum.

2.3 Geometric characteristics

The position of the vertical and horizontal joints must be consistent with the brickwork drawings which are provided before building work begins.

The acceptable sweep of any surface cannot exceed 7 mm along any vertical or horizontal length. Deviation from verticality cannot exceed 5 mm per storey.

Tolerance along the length of the masonry elements is as follows:

For thin walls (<20 cm thick):

- for small size sections of masonry (<100 cm), the tolerance is 5 mm;
- for larger size sections of masonry (>100 cm), the tolerance is 15 mm.

For thick walls (>20 cm thick):

- for small size sections of masonry (<100 cm), the tolerance is 10 mm;
- for larger size sections of masonry (>100 cm), the tolerance is 20 mm.

2.4 Appearance characteristics

2.4.1 Drips

The execution should be flawless and with no drips. All the mortar joints should be perfectly smooth.

2.4.2 Cracks

Micro-cracks:

- can be tolerated on all exposed faces.

Macro-cracks:

Conditions of acceptability for all faces:

- they must not exceed 0.5 mm in width;
- they must not exceed 200 mm in length;
- the presence of tolerated macro-cracks should not be concentrated in or found throughout one part or the whole of the built structure.

2.4.3 Chipped corners

Corners should be perfect and chips at corners are acceptable only within the limit of chipped corners acceptable for facing CEBs.

2.4.4 Colour

The masonry colour will be as homogeneous as possible, other than if for aesthetic reasons, a more varied appearance is required.

2.4.5 Surface texture

The masonry should have a homogeneous surface texture. However, one can seek special effects by introducing different textures in precise areas (e.g. around openings, at corners, etc.)

2.5 Physicochemical characteristics

2.5.1 Pitting

No pitting due to the bursting of expansive materials is tolerated.

2.5.2 Efflorescence

The masonry must not display any significant and lasting efflorescence covering a large area of the surface. A faint whitish film or a thin band are not taken into account.

2.6 Mechanical, hygrometric and physical characteristics

The mechanical, hygrometric and physical characteristics of the masonry are not only a function of the quality of the component products (the compressed earth blocks and the earth mortars), but are also highly dependent on the quality of the workmanship and curing conditions.

2.6.1 Dry characteristic compressive strength of the CEBM wall

The dry characteristic compressive strength (f_k) of the CEBM wall must be at least equal to the dry characteristic compressive stress at the foot of the wall, determined by a static calculation of the vertical load on the masonry, in accordance with the standards in force.

2.6.2 Compressive strength of the CEBs

For CEBMs in a dry or protected environment, the CEBs must have a dry compressive strength (f_b dry) at least equal to 10 times the value of the dry characteristic compressive strength (f_k) required for the wall.

For CEBMs in a wet environment, with no protection against water damage, the CEBs should have a wet compressive strength (f_b wet) at least equal to 10 times the value of the dry characteristic compressive strength (f_k) required for the wall.

The value of the compressive strength of the CEBs fixed in this way will determine the category of resistance of the CEBs to mechanical constraints.

2.6.3 Thermal resistance

The thermal resistance of masonry under internal or external climatic conditions is specified only in the case of masonry expressly designed to provide thermal insulation.

2.6.4 Thermal capacity

Thermal capacity per unit of volume is specified only in the case of masonry specifically intended to provide thermal capacity. Thermal capacity is determined in the light of the project requirements.

2.6.5 Acoustic attenuation coefficient

The acoustic attenuation coefficient is specified only in the case of masonry expressly designed to provide acoustic insulation.

2.6.6 Fire resistance

The fire resistance of masonry is specified only in the case of masonry expressly designed to resist fire.

MANUFACTURING AND ASSEMBLING STANDARDS

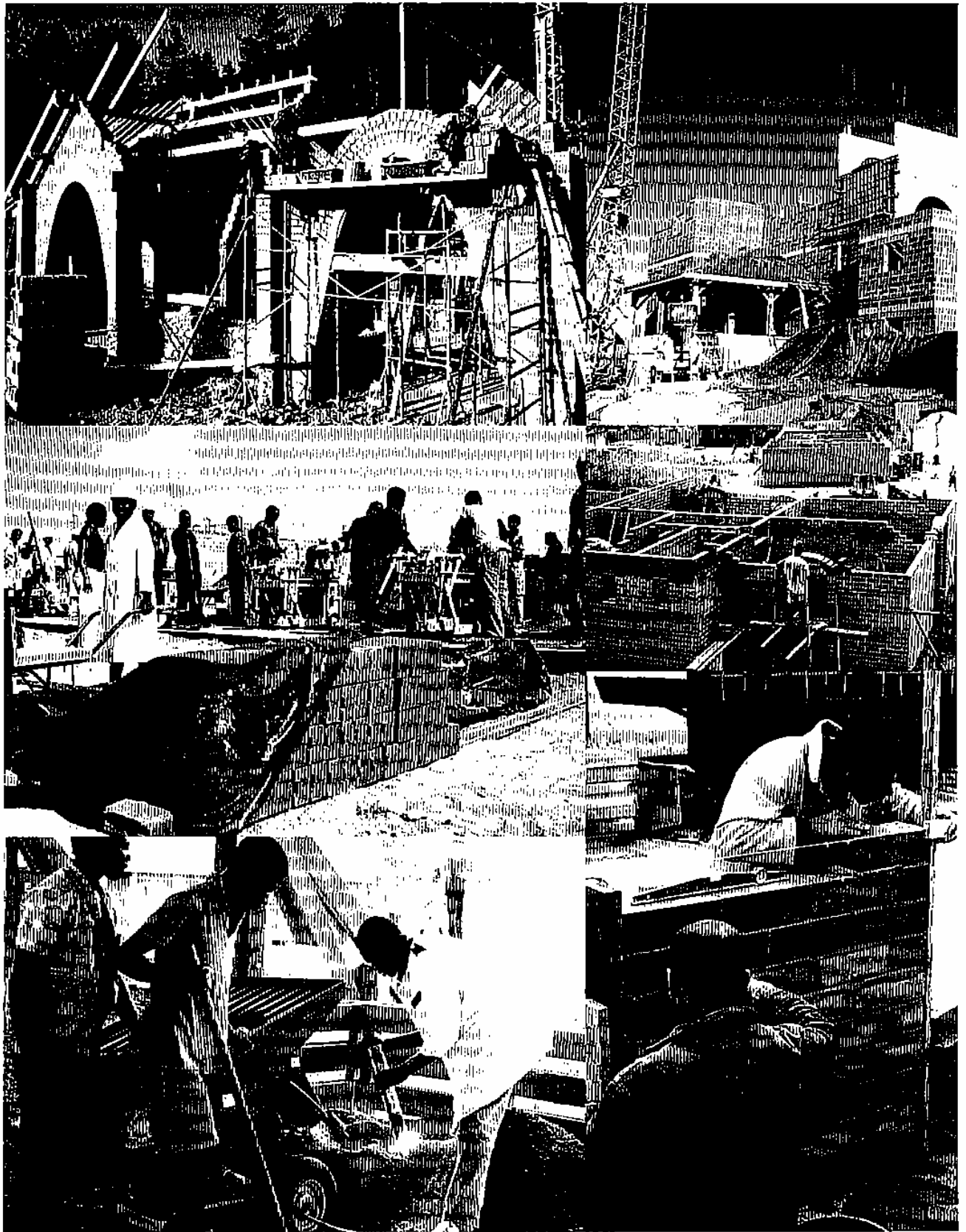

Compressed earth blocks: standards

The uses of compressed earth block technology vary greatly. Not only is there a very wide range of products, but manufacturing and construction processes can be infinitely modified.

However, a good number of basic rules are common to all variations if good results are to be obtained. Alternative practices may also give satisfactory outcomes, but in this event technical and scientific checks will need to be made.

ARS 680: 1996 - Compressed earth blocks
Code of practice for the production of compressed earth blocks

1 General

1.1 Object

This code of practice describes the state of the art relating to the manufacture of compressed earth blocks (CEBs), such as it is known in the light of the current state of the technique.

1.2 Field of application

The rules described in the present code are applicable in all production enterprises operating in the context of public or of private markets.

The standard is not applicable in areas subject to earthquakes, floods or cyclones to an extent that requires the application of appropriate rules in order to avoid major damage.

2 Code of practice

2.1 Recommendations on earth selection

Selecting a suitable type of earth can take place in the field using parameters which are the fruit of experience acquired in the course of operational practice. If any doubt persists, laboratory identification tests should be carried out.

2.1.1 Granular composition

The granular composition of the earth should preferably fall within the limits of the shaded area on the diagram of texture which follows and should be similar in shape.

The limits of the recommended shaded area are approximate.

Types of earth the granular composition of which fall within the recommended shaded area in most cases give satisfactory results.

Types of earth the granular composition of which fall outside the shaded area may still give acceptable results, but it is recommended that they be subjected to a series of tests enabling their suitability to be assessed.

Figure 1 — Diagram of texture

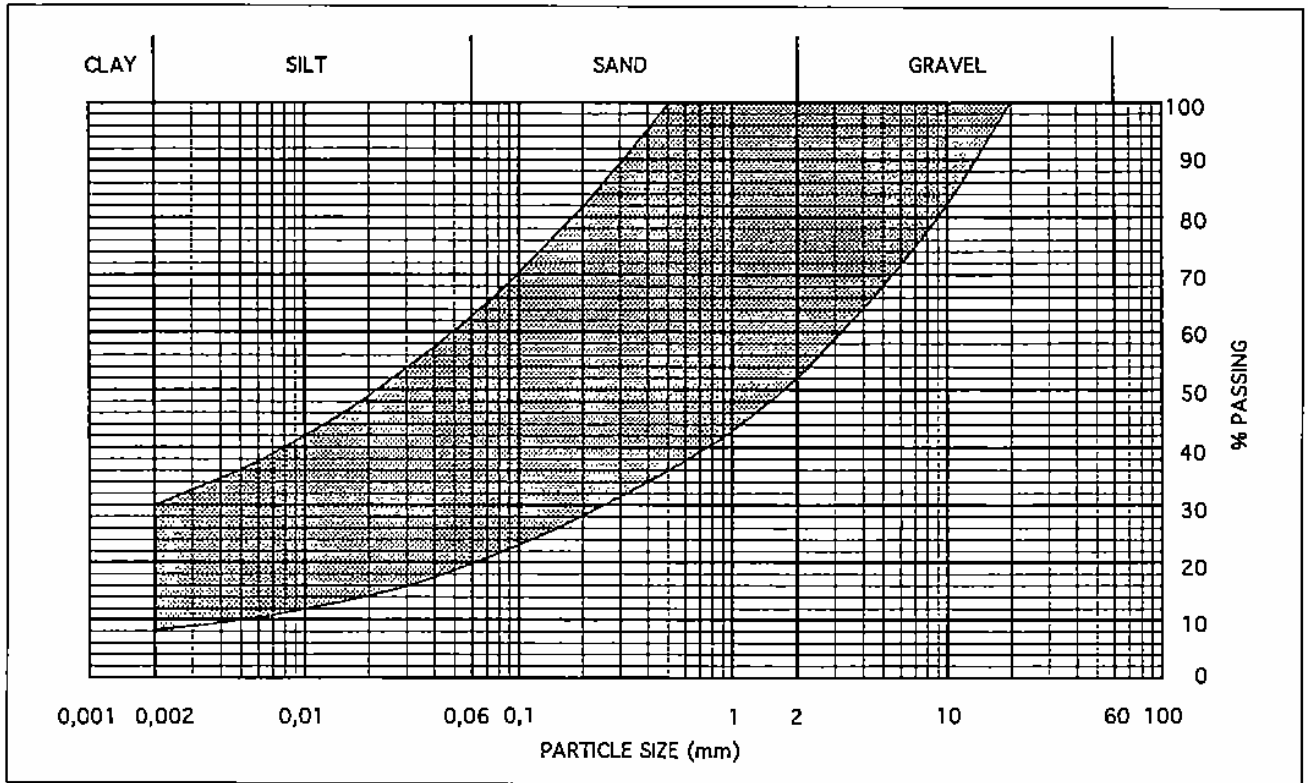

2.1.2 Plasticity

The plasticity of the earth should preferably fall within the limits of the shaded area of the diagram of plasticity which follows.

The limits of the recommended shaded area are approximate.

Types of earth the plasticity of which fall within the recommended shaded area in most cases give satisfactory results.

Types of earth the plasticity of which fall outside the shaded area may still give acceptable results, but it is recommended that they be subjected to a series of tests enabling their suitability to be assessed.

Figure 2 — Diagram of plasticity

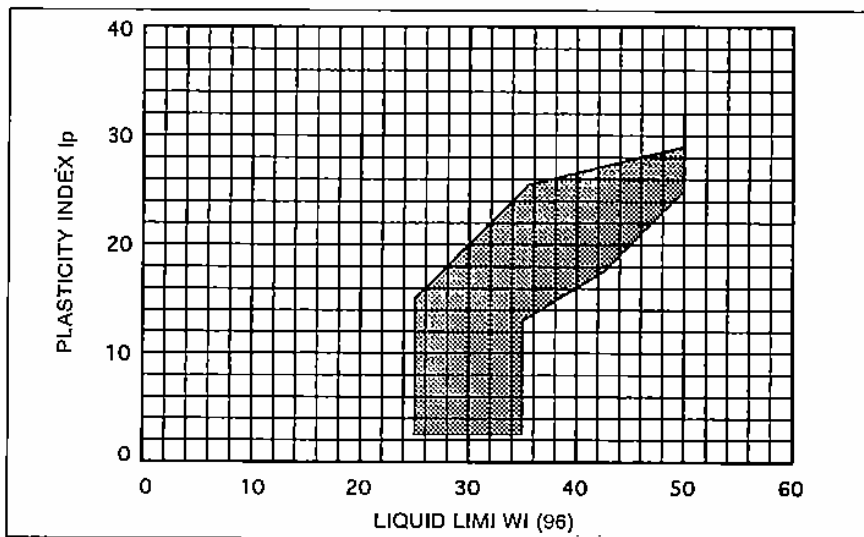

2.1.3 Nature

Table 1 — Classification of materials according to their nature

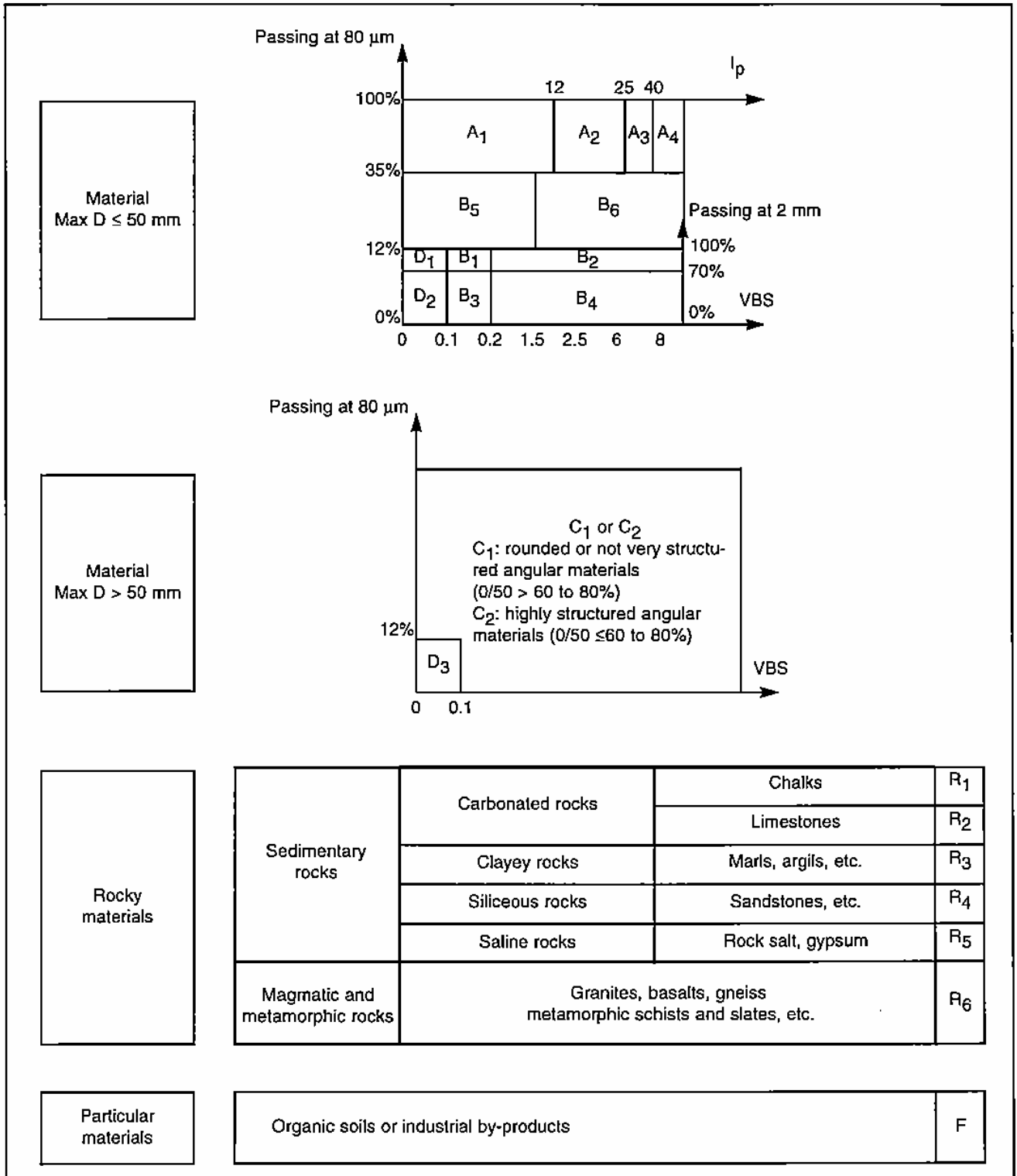

The nature of types of earth is determined by the combination of values resulting from tests for particle size distribution, plasticity and methylene blue value. The overall suitability of soils is as follows:

- A1: an acceptable material but with slightly too many fines.
- A2: an acceptable material but with too many fines.
- A3: an acceptable material but requiring particular care, as it is relatively active.
- A4: a material which is difficult to use, as it is very active.
- B1: a sandy material requiring fines to be added to make it acceptable.
- B2: an acceptable material slightly lacking in fines.
- B3: a sandy material requiring a considerable addition of fines to make it acceptable.
- B4: an acceptable material lacking in fines.
- B5: an acceptable material but slightly lacking in fines.
- B6: an acceptable material but slightly lacking in fines.
- C1: a material containing too much gravel, which should be sieved to change its nature.
- C2: a material containing too much gravel, which should be sieved to change its nature.
- D1: a sandy material requiring fines to be added to make it acceptable.
- D2: a sandy material requiring a considerable addition of fines to make it acceptable.
- D3: a material containing too much gravel, which should be sieved to change its nature and which requires a considerable addition of fines to make it acceptable.
- R: unsuitable materials.
- F: materials requiring advanced identification tests notably with regard to their chemical analysis and mechanical tests in order to be able to determine their suitability. Testing pre-production stage CEBs should be considered.

2.2 Recommendations for the use of stabilisation additives

2.2.1 Precautions to take when stabilising by adding a physicochemical additive

The presence of certain salts or organic materials can affect the efficacy of stabilising by the addition of an additive. In these cases, some chemical analysis should be therefore be undertaken to determine the presence, the value and the concentration of the following factors:

- pH;
- soluble salts;

- acid salts;
- alkaline salts;
- organic matter or humus;
- carbonates;
- sulphates;
- chlorides.

2.2.2 Cement stabilisation

2.2.2.1 Efficacy and dosage

The efficacy of the dosages depends on the texture and structure of the earth, and on how it is used. 4 to 12% of the weight of the dry earth gives good results. Some types of earth require only 3% whereas others, with the same dosage, behave less well than without the cement. In general, at least 6% cement is needed to obtain satisfactory results. Compressive strength remains highly dependent on the dosage.

The dosages indicated are relative to dry weight and are determined in laboratory conditions. Measures for checking in the workshop or on site should take account of the specific hygrometric conditions existing locally.

2.2.2.2 Efficacy parameters

1) *Types of earth*

Almost all types of earth can be stabilised with cement. The best results are obtained with gravely and sandy types of earth. Compression at optimum water content is the most efficient.

2) *Organic matter*

This is recognised as deleterious, and as a general rule, an organic matter content in excess of 1% is risky; earth containing more than 2% should not be used.

3) *Sulphates*

When dry, calcium sulphates, which are frequently found, are less deleterious than magnesium sulphates. When wet, sulphates are always very deleterious. Sulphates destroy the hardened hydraulic binder matrix and increase the sensitivity to humidity of the clays. A specific study for earth containing more than 2 to 3% total sulphate content is indispensable.

4) *Oxides and metallic hydroxides*

Essentially, these are iron and aluminium oxides which are rarely present in excess of around 5% and which in that event have little effect. In types of earth containing more than 5%, stabilisation has been observed to be highly effective with little cement.

5) *Water*

In principle one should reject water containing organic matter and salty water: these may cause efflorescence. Water rich in sulphates may be unfavourable.

2.2.2.3 Types of cement

Portland cements or cements of a similar class are very suitable. Composite cements can also be used. However, suitability tests should be carried out to justify using them. There is no point in using high strength cements which give no particular improvement and which are more expensive.

2.2.2.4 Additives

Certain products, added in small quantities to the earth-cement during mixing, can improve certain of its properties.

1) *Reducing sensitivity to organic matter*

Slaked lime, used at 2%, can reduce the deleterious effect of organic matter, as can calcium chloride (0.3 to 2%) which also accelerates the setting of the cement.

2) *Modifying the plasticity of the earth*

Slaked lime can also be used to modify the plasticity of the earth and to restrict the formation of nodules.

3) *Rendering the earth water-proof*

Bitumens, in emulsion or cut-back, used at 2 to 4%, enable CEBs to be made impermeable.

2.2.3 Lime stabilisation

2.2.3.1 Types of lime

1) *Non-hydraulic limes*

These are produced by calcinating very pure limestone and are the main kinds of lime used in stabilisation.

— *Quicklime (CaO)*: produced directly by calcinating stone containing lime. Its use may be restricted because of the careful storage and handling it requires. Quicklime is highly water absorbent and must be protected from humidity. It is an aggressive material which must be handled with great care: it becomes very hot during the hydration phase (up to 150°C). Weight for weight, it is more efficient than slaked lime because it contains more calcium ions. When the earth is wet, it can absorb the water required for it to be hydrated.

— *Slaked lime (CaOH)₂*: this is obtained by hydrating (slaking) quicklime. Used in stabilisation, it does not have the storage and handling disadvantages of quicklime. Slaked limes should not be too finely ground to be effective. Industrial quality slaked limes contain 90 to 99% «active lime», whereas those of craft production quality can contain as little as 70 to 75% with the remainder being inert material which is either not calcinated or excessively calcinated. Stabilisation dosages should be modified in consequence.

2) *Hydraulic limes*

These resemble cements. They should be considered for use only if there are no other qualities of lime available. Natural hydraulic limes are more efficient for stabilisation than artificial hydraulic limes which are not recommended.

3) *Agricultural limes*

These are used to modify agricultural types of earth and generally have no stabilising effect.

4) *Dolomite limes*

These are suitable for stabilisation, but they set excessively slowly.

2.2.3.2 Efficacy and dosage

By adding 1% quicklime to the earth, the exothermic reaction of hydration dries the earth, removing approximately 0.5 to 1% moisture.

Adding 2 to 3% quicklime immediately causes a fall in the plasticity of the earth and breaks down lumps; this reaction is called the lime fixing point. For ordinary stabilisation using slaked lime, dosages of 4 to 12% are generally used, equivalent to those used with cement, but it should be noted that with lime, there is an optimal quantity for each type of earth.

The dosages indicated are relative to dry weight and are determined in laboratory conditions. Measures for checking in the workshop or on site should take account of the specific hygrometric conditions existing locally.

2.2.3.3 Efficacy parameters

1) *Types of earth*

These should contain a reasonable clay fraction. Results vary depending on the nature of the clay minerals and are good with those which are high in aluminium silicate, in silica, and in iron hydroxide. Natural pozzolanas react quickly and well with lime.

2) *Organic matter*

This can prevent ion exchanges in clayey types of earth, without however, preventing the pozzolanic reaction.

Types of earth containing up to 20% organic matter can be stabilised with lime but care must be taken.

3) *Sulphates*

When dry, calcium sulphates, which are frequently found, are less deleterious than magnesium sulphates. When wet, sulphates are always very deleterious. Sulphates destroy the hardened hydraulic binder matrix and increase the sensitivity to humidity of the clays. A specific study for earth containing more than 2 to 3% total sulphate content is indispensable.

2.2.3.4 Additives

Certain additives mixed with lime can produce special effects.

1) *Increasing compressive strength*

- Portland cement or composite cement with a variable dosage which can be up to 100% of the lime dosage.

2) *Rendering the treated earth water-proof*

- bituminous products;
- other waterproofing agents.

2.2.4 Stabilising using commercial products

Using commercial products other than cement and lime to stabilise the earth with a view to manufacturing compressed earth blocks should be examined beforehand by an approved testing laboratory to establish the genuine efficacy of the product.

2.3 Recommendations for manufacturing parameters

Poor execution of any one of the manufacturing stages will considerably lower the quality of the CEBs.

2.3.1 Stocking raw materials

2.3.1.1 Stocking the earth

Earth which has been taken delivery of should be stocked in such a manner as to avoid any pollution from another type of earth or any other material. The earth should also be protected from accidentally being moistened.

2.3.1.2 Stocking additives

Stocking additives should be arranged so that they are protected from bad weather and so that there is a rapid turnover between delivery and use.

2.3.2 Preparing the mix

At the end of the preparation, the earth should have a water content below the optimum water content for compression and if possible it should be dry (water content $\leq 5\%$). No grain or particle should have a diameter in excess of 20 mm and preferably not in excess of 10 mm, the ideal being around 5 mm.

If on completion of the preparation stage, the earth falls outside the recommended zones of texture and plasticity, it should be corrected by adding a filler until it comes back within the recommended zones. If even after correction, the mix is still outside the recommended areas, another type of earth will have to be sought or the suitability of the mix will have to be specifically examined by an approved laboratory.

2.3.2.1 Screening the earth

This operation aims to eliminate all components with a diameter in excess of that required. However, these components can be made up of aggregates or agglomerates made up of fines which will equally be eliminated, whereas they are required to ensure the cohesion of the final product. It is therefore preferable to break down these agglomerates by a pulverisation operation.

2.3.2.2 Pulverising the earth

This is an important operation and must be carried out with great care. The more finely the clay and the silt are broken down, the more homogeneous the earth will be, and in the event of stabilisation, the more efficient the action of the stabiliser. The operation can be a difficult one as clay is highly cohesive. There should not be too great a concentration of fines in agglomerates the size of which should not exceed 10 mm. The presence of 50% by weight of agglomerates of fines of ≥ 5 mm in size can reduce compressive strength by half. Certain types of earth still require screening after pulverisation.

2.3.2.3 Mixing

The homogeneity of the material depends on the quality of the mixing. It is important to use dry earth to obtain best mixing conditions.

In wet regions, this may mean drying out the earth beforehand. Mixing can accelerate the drying process and help to break down lumps. The water required for mixing should be sprinkled or sprayed in and only at the end of the mixing process, after a required phase of dry mixing.

The water should be added gradually until a homogeneous mix with optimum water content has been obtained, the optimum water content having been determined beforehand by tests.

Mixing in an additive should be done dry except in the particular case of products requiring wet mixing. Mixing should continue until a homogeneous mix has been obtained.

The time needed for manual or mechanised mixing depends on the mixing time required to obtain a perfectly homogeneous mix; this can be assessed by its uniform colour, and no streaks should be visible.

2.3.3 Manufacturing the CEBs

2.3.3.1 Retention time of the mix

When the mixing has been with added cement, the mix should be used within half an hour of the beginning of the wet mixing stage.

When the mixing has been with added non-hydraulic lime, the mix can be used after several hours.

Any precautions needed to prevent water evaporation from the mix must be taken in order to maintain the optimum water content of the mix at the required level.

2.3.3.2 Compressing the CEBs

The mix should be compressed at a water content which has been checked, close to the optimum water content. A 2% deviation in water content, either higher or lower, will very significantly reduce the quality of the CEBs. The higher the pressure during compression, the greater the harmful effect of any deviation from the optimum water content on the quality of the CEBs will be.

Compression takes place after filling the mould with an optimum volume of mix. Pressure should be maintained for at least one second at the end of compression. The press manufacturer's particular recommendations should be followed to obtain the best level of compression, at the end of compression.

2.3.3.3 Curing the CEBs

The way curing is organised should be suited both to local hygrometric conditions and to the nature of the CEBs (non-stabilised or stabilised).

Conditions for drying and curing should be determined in the light of the evaporation values observed locally during the period in question. Evaporation varies depending on a relationship between air temperature, humidity and speed. Except when the air is saturated, air movements should be restricted. The higher the ambient temperature, the more care must be taken to maintain a high degree of relative air humidity for at least one week after demoulding. In the case of low ambient temperature, care should be taken to restrict heat losses.

In the case of cement stabilisation, 14 days curing are absolutely indispensable, and 28 days are recommended.

In the case of lime stabilisation, 30 days curing are absolutely indispensable and 90 days are recommended.

Cement and lime stabilised CEBs should be kept in a humid environment, protected from the harmful effects of the sun and out of the wind: too fast a surface drying can result in shrinkage cracks appearing. Stabilised CEBs must be stocked in a compact configuration, moistened by sprinkling or covered with plastic sheeting which maintains temperatures at a beneficially high level whilst giving a relative humidity of close to 100%.

3 Checking procedures

3.1 Raw materials

3.1.1 Earth

See «Conditions for taking delivery of earth supplies».

3.1.2 Stabilising additives

1) Procedure

- for cements, tests on samples of standard cement mortar;
- for lime, chemical composition tests.

2) Frequency

- at each delivery.

3.1.3 Water

1) Procedure

- in the case of a manufacturing process with stabilisation using an additive with a physicochemical effect (Portland cement, lime), analysis of the content of salts and of the pH value.

2) Frequency

- once during the «running in» period, then annually.

3.2 Preparation of the earth

1) Procedure

- wet screening of the prepared earth and calculation of the percentage by weight of grains the diameter of which is between 5 and 10 mm and in excess of 10 mm.

2) Frequency

- weekly during the start-up period, less frequently once production is established.

3.3 Mixing

3.3.1 Earth and additive dosage

1) Procedure

- weighing and measuring volume directly or calculating consumption periodically (e.g. the number sacks of stabiliser consumed per number of blocks produced).

2) Frequency

- frequently and without warning.

3.3.2 Mix

1) Procedure

- visual examination of the homogeneity of the mix;
- timing the average mixing time;
- measuring the water content before use by quick drying and weighing, or measuring using a moisture gauge, or using the dropping ball test.

2) Frequency

- weekly or more.

3.4 Waiting time before use

1) Procedure

- timing the average waiting time.

2) Frequency

- weekly or more.

3.5 Compression

3.5.1 Density

1) Procedure

- weighing the wet block;
- resistance to the penetrometer;
- visual examination.

2) Frequency

- daily.

3.5.2 Geometry

1) Procedure

- measuring the dimensions and checking the geometry of the blocks.

2) Frequency

- weekly.

3.6 Curing

1) Procedure

- visual examination (shrinkage cracks, surface drying out);
- measuring the temperature and the humidity of the atmosphere around the blocks;
- weighing the blocks.

2) Frequency

- weekly.

4 Conditions for taking delivery of earth supplies

4.1 General

4.1.1 Types of check on taking delivery

There are two types of check on taking delivery:

— a simple check, which relates solely to the comparative examination of the appearance, the simplified sedimentation test and sand equivalent test of the earth supplied compared with the values recorded in the reference earth type selected when ordering;

— a complete check, which relates to measuring texture and plasticity and the presence of organic matter and sulphates with the values of the sample of reference earth type.

4.1.2 Choosing the type of check on taking delivery

The buyer is free to choose the type of check on taking delivery.

If the buyer requires that a complete check should be carried out, it is preferable for him to inform the supplier of this in writing on the order document.

Carrying out laboratory tests intended to check product conformity to reference values normally requires a minimum of two weeks.

4.1.3 Date and place of taking delivery

Taking delivery occurs at the moment the buyer assumes responsibility for the products, i.e. either at the supplier location or at the delivery location.

If it takes place at the supplier location, the date should be mutually agreed. The buyer should be present or represented.

If it takes place at the delivery location, the date should be indicated to the supplier who has the right to be present at the operations relating to taking delivery, or to be represented there by a person attending on his behalf.

Unless specifically stated, taking delivery can occur at the delivery location only if the supplier is responsible for the transport.

4.2 Taking delivery on site

As soon as the earth has been unloaded and before any subsequent handling in the production plant, the buyer should proceed with an overall examination of the appearance of the earth.

If this examination shows that the earth delivered is not homogeneous in nature, after due hearing of the parties, one may proceed, at the supplier's expense, to sort it with a view to separating the *a priori* acceptable types of earth from the rest of the delivery.

If the earth is homogeneous in nature, one should proceed with the operations for taking delivery properly speaking.

4.3 Simple check on taking delivery

4.3.1 Samples

For each delivery, take a sample at random and below the surface of four buckets of earth at four points from the bottom of the pile and two buckets from the upper part of the pile.

Having carried out the simple sedimentation test examination of appearance and that of sand equivalent, these products should be returned to the delivery.

4.3.2 Conditions of acceptability

If the results of the examination give values corresponding to the reference values, the delivery should be accepted.

4.4 Complete check on taking delivery

4.4.1 Examination of appearance

The complete check on taking delivery includes, first, examining appearance as defined above.

Complete checks on taking delivery are carried out in the manner described below.

4.4.2 Samples from the lots

4.4.2.1 Deliveries of up to or equal to 7 tonnes or 5 m³

No sample is taken if the delivery is up to or equal to 7 tonnes or 5 m³ in volume. Consequently, visual examination is sufficient.

4.4.2.2 Deliveries of over 7 tonnes or 5 m³

Split the delivery into lots of maximum 7 tonnes or 5 m³.

4.4.2.3 Particular case of supply occurring on several sites

When delivery is taken on the supplier location, split the complete supply into lots of maximum 21 tonnes or 15 m³.

When delivery is taken on site where it is common to several sites, the reference site is selected by the entrepreneur, who advises the supplier of this in writing.

4.4.2.4 Samples

The samples must be taken on the basis of a sampling process the procedure for which is defined by the standards for testing.

4.4.3 Conditions of acceptability

If, for each of the tests carried out, the results conform to the reference values, the delivery should be accepted.

If this is not the case, one may proceed with a counter-expertise for the test which failed to give satisfaction.

If the results of the counter-expertise are still unfavourable, the delivery can be refused. If the result is favourable, the whole delivery should be accepted.

4.4.4 Choice of laboratory

Tests are carried out on site, in a workshop or in a laboratory selected by mutual agreement between the supplier and the buyer.

4.4.5 Costs of taking delivery

The costs of taking delivery are borne by the buyer if the conditions of acceptability are satisfactory and borne by the supplier if they are not.

4.5 Particular case

The preceding measures do not preclude, by mutual consent, the buyer and the supplier proceeding with partial checks, relating only to certain reference values.

5 Conditions of acceptability of CEB supplies

5.1 General

5.1.1 Types of check on taking delivery

There are two types of check on taking delivery:

- the simple check, which relates solely to examining dimensions and appearance, as defined in the standards and measuring the apparent density;
- the complete check, which relates to all the specifications described by the standards.

5.1.2 Choosing the type of check on taking delivery

The buyer is free to choose the type of check on taking delivery.

If the buyer requires that a complete check should be carried out, it is preferable for him to inform the supplier of this in writing on the order document.

In the event of being supplied by a wholesaler, conditions for taking delivery are valid only for homogeneous lots from the same production plant.

5.1.3 Date and place of taking delivery

Taking delivery occurs at the moment the buyer assumes responsibility for the products, i.e. either at the supplier location or at the delivery location.

If it takes place at the supplier location, the date should be mutually agreed. The buyer should be present or represented.

If it takes place at the delivery location, the date should be indicated to the supplier who has the right to be present at the operations relating to taking delivery or to be represented there by a person attending on his behalf.

Unless specifically stated, taking delivery can occur at the delivery location only if the supplier is responsible for the transport.

5.2 Taking delivery on site

As soon as the CEBs have been unloaded and before any subsequent handling on site, the buyer should proceed with a overall examination of the appearance of the CEBs.

If this examination shows that the number of products which do not conform to the specifications of dimension, appearance or apparent density appears to exceed 10%, after due hearing of the parties, one may proceed, at the suppliers' expense, to sort them with a view to separating the products assumed to conform from the rest of the delivery.

If the number of CEBs displaying defects appears to be less than the percentage thus defined, or when the products have been sorted, one should proceed,

if the buyer requests this, with the operations for taking delivery properly speaking.

5.3 Simple check on taking delivery

5.3.1 Samples

For each delivery, take at random 1 CEB out of every 300, with a minimum of 20 CEBs being sampled.

Having examined them for dimensions, appearance and weight, these products should be returned to the delivery.

5.3.2 Conditions of acceptability

If the results of the examination satisfy the specifications as defined in the standards, the delivery should be accepted.

5.4 Complete check on taking delivery

5.4.1 Examination of dimensions, appearance and weight

The complete check on taking delivery includes, first, the examination for dimensions, appearance and weight as defined in the standards.

Complete checks on taking delivery are further carried out in the manner described below.

5.4.2 Samples from the lots

5.4.2.1 Deliveries of up to or equal to 7 tonnes or 4 m³

No sample is taken if the delivery is up to or equal to 7 tonnes or 4 m³ in volume. Consequently, visual examination is sufficient.

5.4.2.2 Deliveries of over 7 tonnes or 4m³

Split the delivery into lots of maximum 21 tonnes or 12 m³.

5.4.2.3 Particular case of supply occurring on several sites

When delivery is taken on the supplier location, split the complete supply into lots of maximum 21 tonnes or 12 m³.

When delivery is taken on site where it is common to several sites, the reference site is selected by the entrepreneur, who advises the supplier of this in writing.

5.4.2.4 First lot

Take at random minimum 20 blocks intended to be subjected to the tests detailed in the standards.

5.4.2.5 Subsequent lots

Take a minimum of 6 additional CEBs for each 21 tonnes or 12 m³ lot or fraction of lot in excess of 7 tonnes or 4 m³ of blocks.

Half of these CEBs will be used for the compressive strength test.
The other half will be used for other tests, agreed upon by common consent.

5.4.3 Conditions of acceptability

If, for each of the tests carried out, the results conform to the specifications of the order, the delivery should be accepted.

If this is not the case, one may proceed with a counter-expertise for the test which failed to give satisfaction.

If the results of the counter-expertise are still unfavourable, the delivery can be refused. If the result is favourable, the whole delivery should be accepted.

5.4.4 Choice of laboratory

Tests are carried out on site, in a workshop or in a laboratory selected by mutual agreement between the supplier and the buyer.

5.4.5 Costs of taking delivery

The costs of taking delivery are borne by the buyer if the conditions of acceptability are satisfactory and borne by the supplier if they are not.

5.5 Particular case

The preceding arrangements do not preclude, by mutual consent, the buyer and the supplier proceeding with partial checks, relating only to certain reference values.

6 Annexe

It is recommended that the following technical document be consulted:

- Compressed earth blocks. Vol. I. Manual of production. CRATerre-EAG: Rigassi V., Aus der Arbeit von GATE. Friedrich Vieweg & Sohn, Braunschweig/Wiesbaden, Germany, 1995;

ARS 681: 1996 - Compressed earth blocks

Code of practice for the preparation of earth mortars

1 General

1.1 Object

This code of practice describes the state of the art relating to the manufacture of earth mortar (EM), such as it is known in the light of the current state of the technique.

1.2 Field of application

The rules described in the present code are applicable in all construction enterprises operating in the context of public or of private markets.

The standard is not applicable in areas subject to earthquakes, floods or cyclones to an extent that requires the application of appropriate rules in order to avoid major damage.

2 Code of practice

2.1 Recommendations on earth selection

Selecting a suitable type of earth can take place in the field using parameters which are the fruit of experience acquired in the course of operational practice. If any doubt persists, laboratory identification tests should be carried out.

2.1.1 Granular composition

The granular composition of the earth should preferably fall within the limits of the shaded area on the diagram of texture which follows and should be similar in shape.

The limits of the recommended shaded area are approximate.

Types of earth the granular composition of which fall within the recommended shaded area in most cases give satisfactory results.

Types of earth the granular composition of which fall outside the shaded area may still give acceptable results, but it is recommended that they be subjected to a series of tests enabling their suitability to be assessed.

Figure 1 — Diagram of texture

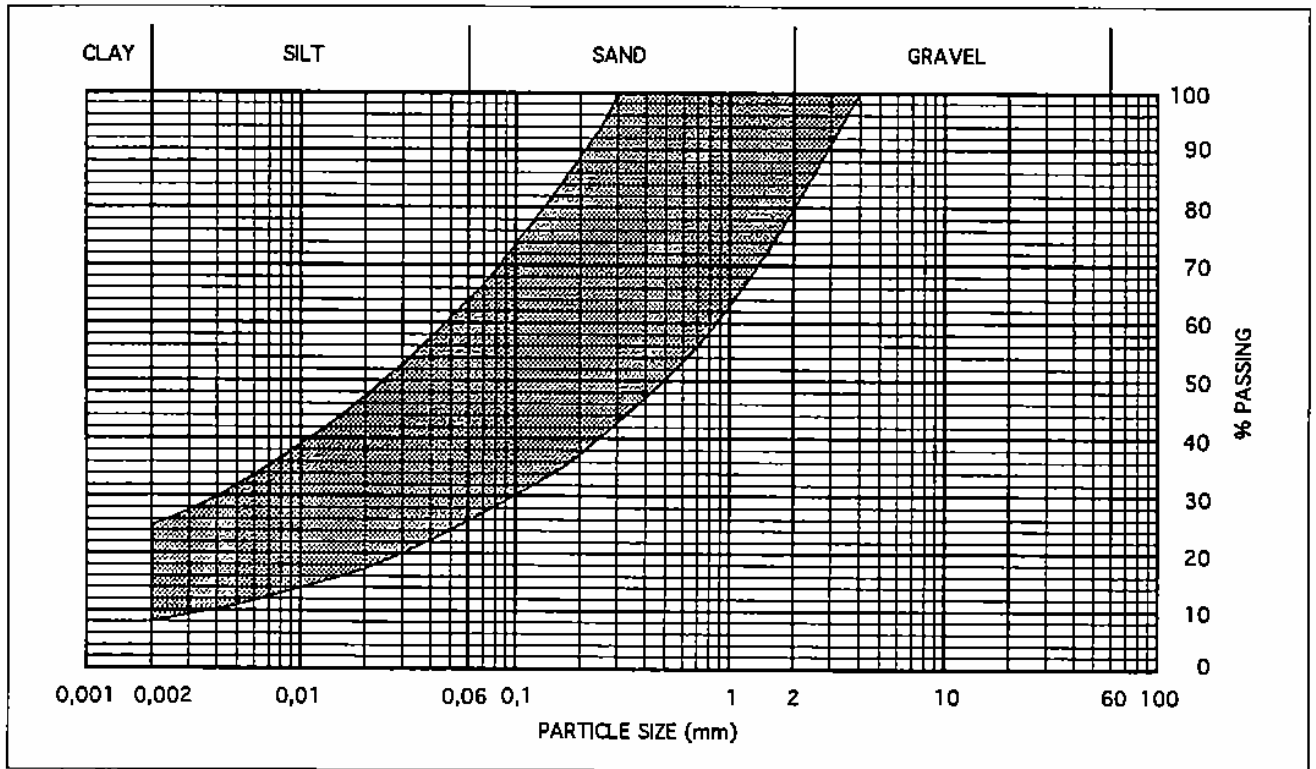

2.1.2 Plasticity

The plasticity of the soil should preferably fall within the limits of the shaded area of the diagram of plasticity which follows.

The limits of the recommended shaded area are approximate.

Types of earth the plasticity of which fall within the recommended shaded area in most cases give satisfactory results.

Types of earth the plasticity of which fall outside the shaded area may still give acceptable results, but it is recommended that they be subjected to a series of tests enabling their suitability to be assessed.

Figure 2 — Diagram of plasticity

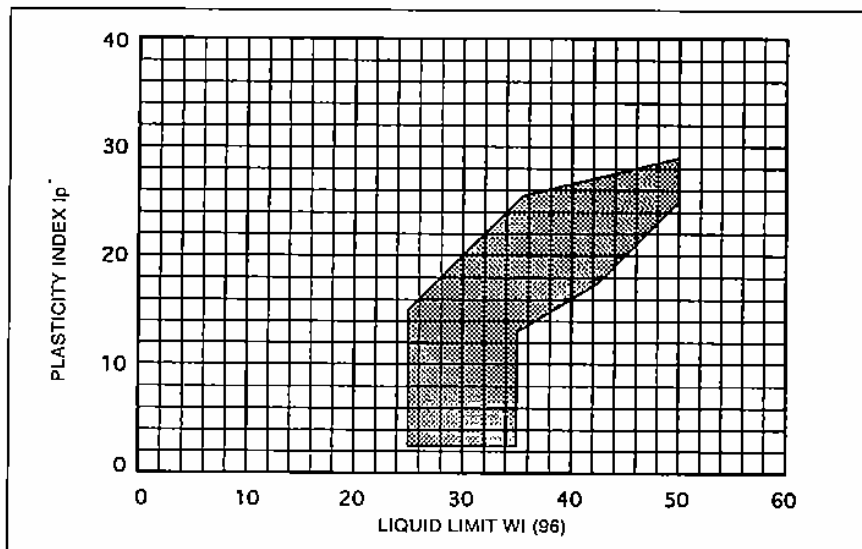

2.1.3 Nature

Table 1 — Classification of materials according to their nature

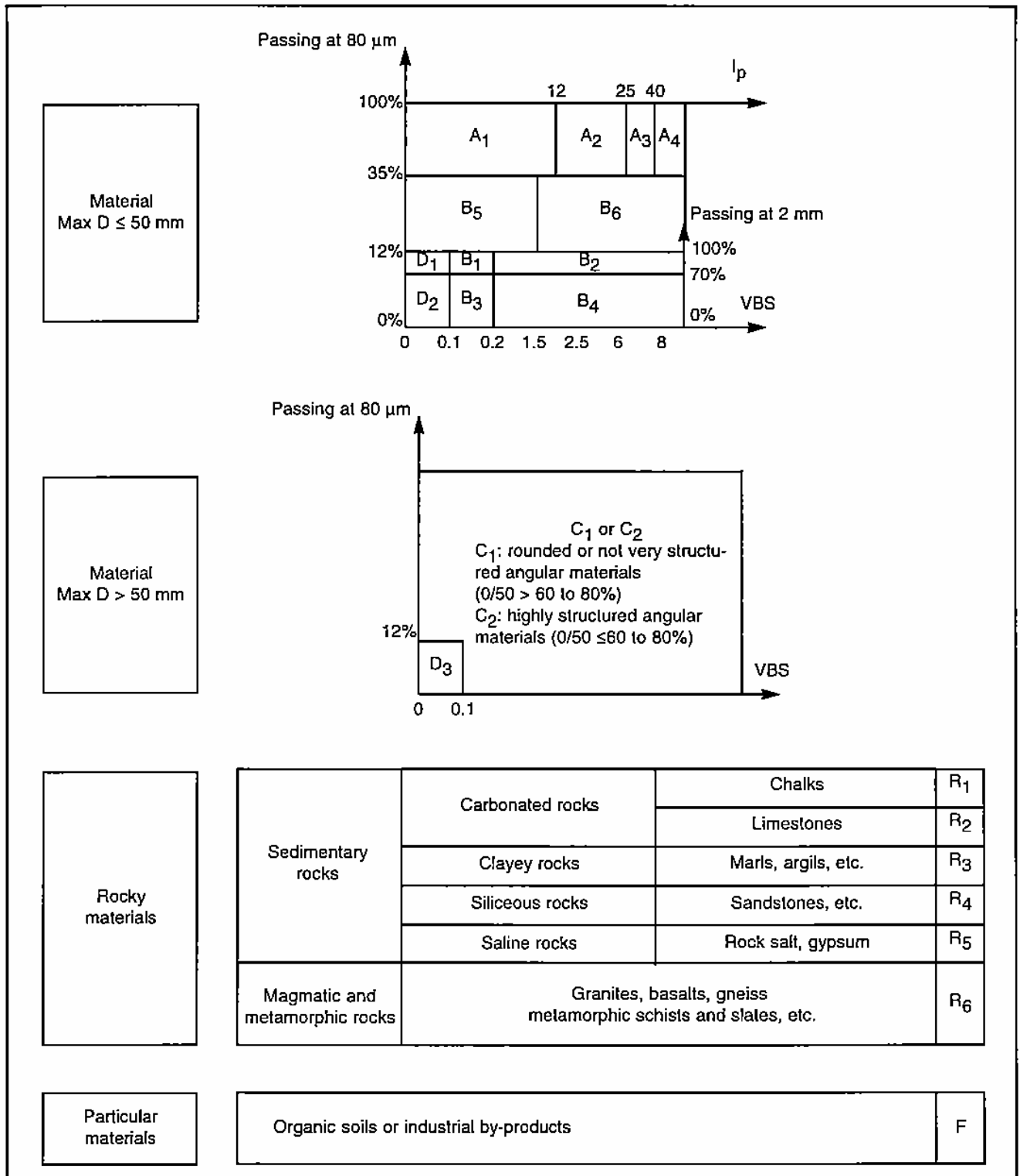

The nature of types of earth is determined by the combination of values resulting from tests for particle size distribution, plasticity and methylene blue value. The overall suitability of types of earth is as follows:

- A1: an acceptable material but with slightly too many fines.
- A2: an acceptable material but with too many fines.
- A3: an acceptable material but requiring particular care, as it is relatively active.
- A4: a material which is difficult to use, as it is very active.
- B1: a sandy material requiring fines to be added to make it acceptable.
- B2: an acceptable material slightly lacking in fines.
- B3: a sandy material requiring a considerable addition of fines to make it acceptable.
- B4: an acceptable material lacking in fines.
- B5: an acceptable material but slightly lacking in fines.
- B6: an acceptable material but slightly lacking in fines.
- C1: a material containing too much gravel, which should be sieved to change its nature.
- C2: a material containing too much gravel, which should be sieved to change its nature.
- D1: a sandy material requiring fines to be added to make it acceptable.
- D2: a sandy material requiring a considerable addition of fines to make it acceptable.
- D3: A material containing too much gravel, which should be sieved to change its nature and which requires a considerable addition of fines to make it acceptable.
- R: unsuitable materials.
- F: materials requiring advanced identification tests notably with regard to their chemical analysis and mechanical tests in order to be able to determine their suitability. Testing pre-production stage CEBs should be considered.

2.2 Recommendations for the use of stabilisation additives

2.2.1 Precautions to take when stabilising by adding a physicochemical additive

The presence of certain salts or organic materials can affect the efficacy of stabilising by the addition of an additive. In these cases, some chemical analysis should be therefore be undertaken to determine the presence, the value and the concentration of the following factors:

- pH;
- soluble salts;

- acid salts;
- alkaline salts;
- organic matter or humus;
- carbonates;
- sulphates;
- chlorides.

2.2.2 Cement stabilisation

2.2.2.1 Efficacy and dosage

As earth mortars are used in a plastic state, up to 50 % more cement is sometimes required to obtain the same efficacy as when using the same type of earth, compressed in a humid state, for the manufacture of CEBs.

The efficacy of the dosages depends on the texture and structure of the earth, and on how it is used. 6 to 12% of the weight of the dry earth generally gives good results. Compressive strength remains highly dependent on the dosage.

The dosages indicated are relative to dry weight and are determined in laboratory conditions. Measures for checking in the workshop or on site should take account of the specific hygrometric conditions existing locally.

2.2.2.2 Efficacy parameters

1) *Types of earth*

Almost all types of earth can be stabilised with cement. The best results are obtained with sandy types of earth.

2) *Organic matter*

This is recognised as deleterious, and as a general rule, an organic matter content in excess of 1% is risky; earth containing more than 2% should not be used.

3) *Sulphates*

When dry, calcium sulphates, which are frequently found, are less deleterious than magnesium sulphates. When wet, sulphates are always very deleterious. Sulphates destroy the hardened hydraulic binder matrix and increase the sensitivity to humidity of the clays. A specific study for earth containing more than 2 to 3% total sulphate content is indispensable.

4) *Oxides and metallic hydroxides*

Essentially, these are iron and aluminium oxides which are rarely present in excess of around 5% and which in that event have little effect. In types of earth containing more than 5%, stabilisation has been observed to be highly effective with little cement.

5) *Water*

In principle one should reject water containing organic matter and salty water: these may cause efflorescence. Water rich in sulphates may be unfavourable.

2.2.2.3 Types of cement

Portland cements or cements of a similar class are very suitable. Composite cements can also be used. However, suitability tests should be carried out to justify using them. There is no point in using high strength cements which give no particular improvement and which are more expensive.

2.2.2.4 Additives

Certain products, added in small quantities to the earth-cement during mixing, can improve certain of its properties.

1) *Reducing sensitivity to organic matter*

Slaked lime, used at 2%, can reduce the deleterious effect of organic matter, as can calcium chloride (0.3 to 2%) which also accelerates the setting of the cement.

2) *Modifying the plasticity of the earth*

Slaked lime can also be used to modify the plasticity of the soil and to restrict the formation of nodules.

3) *Rendering the earth water-proof*

Bitumens, in emulsion or cut-back, used at 2 to 4%, enable mortars to be made impermeable.

2.2.3 Lime stabilisation

2.2.3.1 Types of lime

1) *Non-hydraulic limes*

These are produced by calcinating very pure limestone and are the main kinds of lime used in stabilisation.

— *Quicklime (CaO)*: produced directly by calcinating stone containing lime. Its use may be restricted because of the careful storage and handling it requires. Quicklime is highly water absorbent and must be protected from humidity. It is an aggressive material which must be handled with great care: it becomes very hot during the hydration phase (up to 150°C). Weight for weight, it is more efficient than slaked lime because it contains more calcium ions. When the earth is wet, it can absorb the water required for it to be hydrated.

— *Slaked lime (CaOH)₂*: this is obtained by hydrating (slaking) quicklime. Used in stabilisation, it does not have the storage and handling disadvantages of quicklime. Slaked limes should not be too finely ground to be effective. Industrial quality slaked limes contain 90 to 99% «active lime», whereas those of craft production quality can contain as little as 70 to 75% with the remainder being inert material which is either not calcinated or excessively calcinated. Stabilisation dosages should be modified in consequence.

2) *Hydraulic limes*

These resemble cements. They should be considered for use only if there are no other qualities of lime available. Natural hydraulic limes are more efficient for stabilisation than artificial hydraulic limes which are not recommended.

3) *Agricultural limes*

These are used to modify agricultural types of earth and generally have no stabilising effect.

4) *Dolomite limes*

These are suitable for stabilisation, but they set excessively slowly.

2.2.3.2 Efficacy and dosage

By adding 1% quicklime to the earth, the exothermic reaction of hydration dries the earth, removing approximately 0.5 to 1% moisture.

Adding 2 to 3% quicklime immediately causes a fall in the plasticity of the earth and breaks down lumps; this reaction is called the lime fixing point. For ordinary stabilisation using slaked lime, dosages of 4 to 12% are generally used, equivalent to those used with cement, but it should be noted that with lime, there is an optimal quantity for each type of earth.

The dosages indicated are relative to dry weight and are determined in laboratory conditions. Measures for checking in the workshop or on site should take account of the specific hygrometric conditions existing locally.

2.2.3.3 Efficacy parameters

1) *Types of earth*

These should contain a reasonable clay fraction. Results vary depending on the nature of the clay minerals and are good with those which are high in aluminium silicate, in silica, and in iron hydroxide. Natural pozzolanas react quickly and well with lime.

2) *Organic matter*

This can prevent ion exchanges in clayey soils, without however, preventing the pozzolanic reaction.

Types of earth containing up to 20% organic matter can be stabilised with lime but care must be taken.

3) *Sulphates*

When dry, calcium sulphates, which are frequently found, are less deleterious than magnesium sulphates. When wet, sulphates are always very deleterious. Sulphates destroy the hardened hydraulic binder matrix and increase the sensitivity to humidity of the clays. A specific study for earth containing more than 2 to 3% total sulphate content is indispensable.

2.2.3.4 Additives

Certain additives mixed with lime can produce special effects.

1) *Increasing compressive strength*

- Portland cement or composite cement with a variable dosage which can be up to 100% of the lime dosage.

2) *Rendering the treated earth water-proof*

- bituminous products;
- other waterproofing agents.

2.2.4 Stabilising using commercial products

Using commercial products other than cement and lime to stabilise the earth with a view to manufacturing earth mortars should be examined beforehand by an approved testing laboratory to establish the genuine efficacy of the product.

2.3 Recommendations for manufacturing parameters

Poor execution of any one of the manufacturing stages will considerably lower the quality of the EMs.

2.3.1 Stocking raw materials

2.3.1.1 Stocking the earth

Earth which has been taken delivery of should be stocked in such a manner as to avoid any pollution from another type of earth or any other material.

The earth should also be protected from accidentally being moistened.

2.3.1.2 Stocking additives

Stocking additives should be arranged so that they are protected from bad weather and so that there is a rapid turnover between delivery and use.

2.3.2 Preparing the mix

At the end of the preparation, the earth should be as dry as possible (water content $\leq 5\%$). No grain or particle should have a diameter in excess of 4 mm and preferably not in excess of 2 mm.

If on completion of the preparation stage, the earth falls outside the recommended zones of texture and plasticity, it should be corrected by adding a filler until it comes back within the recommended zones. If even after correction, the mix is still outside the recommended areas, another type of earth will have to be sought or the suitability of the mix will have to be specifically examined by an approved laboratory.

2.3.2.1 Screening the earth

This operation aims to eliminate all components with a diameter in excess of that required. However, these components can be made up of aggregates or agglomerates made up of fines which will equally be eliminated, whereas they are required to ensure the cohesion of the final product. It is therefore preferable to break down these agglomerates by a pulverisation operation.

2.3.2.2 Pulverising the earth

This is an important operation and must be carried out with great care. The more finely the clay and the silt is broken down, the more homogeneous the earth will be, and in the event of stabilisation, the more efficient the action of the stabiliser. The operation can be a difficult one as clay is highly cohesive. There should not be too great a concentration of fines in agglomerates the size of which should not exceed 4 mm. The presence of 50% by weight of agglomerates of fines of ≥ 4 mm in size can reduce compressive strength by half. Certain types of earth still require screening after pulverisation.

2.3.2.3 Mixing

The homogeneity of the material depends on the quality of the mixing. It is important to use dry earth to obtain best mixing conditions.

In wet regions, this may mean drying out the earth beforehand. Mixing can accelerate the drying process and help to break down lumps. The water required for mixing should be sprinkled or sprayed in and only at the end of the mixing process, after a required phase of dry mixing.

The water should be added gradually until a smooth and homogeneous mix has been obtained.

Mixing in an additive should be done dry except in the particular case of products requiring wet mixing. Mixing should continue until a homogeneous mix has been obtained.

The time needed for manual or mechanised mixing depends on the mixing time required to obtain a perfectly homogeneous mix; this can be assessed by its uniform colour, and no streaks should be visible.

2.3.3 Using the EM

2.3.3.1 Retention time of the mix

The earth mortar should be plastic and smooth and should hold on the trowel. Liquid earth mortars should not be used.

Any precautions needed to prevent water evaporation from the EM must be taken in order to maintain the plasticity and the smoothness at the required level.

When the mixing has been with added cement, the EM should be used within half an hour of the beginning of the wet mixing stage.

When the mixing has been with added non-hydraulic lime, the EM can be used after several hours.

Any precautions needed to prevent water evaporation from the mix must be taken in order to maintain the right water content of the mix at the required level.

3 Checking procedures

3.1 Raw materials

3.1.1 Earth

See «Conditions for taking delivery of earth supplies».

3.1.2 Stabilising additives

1) Procedure

- for cements, tests on samples of standard cement mortar;
- for lime, chemical composition tests.

2) Frequency

- at each delivery.

3.1.3 Water

1) Procedure

- in the case of a manufacturing process with stabilisation using an additive with a physicochemical effect (Portland cement, lime), analysis of the content of salts and of the pH value.

2) Frequency

- once during the «running in» period, then annually.

3.2 Preparing the earth

1) Procedure

- wet screening of the prepared earth and calculation of the percentage by weight of grains the diameter of which is in excess of 4 mm.

2) Frequency

- weekly during the start-up period, less frequently once production is established.

3.3 Mixing

3.3.1 Earth and additive dosage

1) Procedure

- weighing and measuring volume directly or calculating consumption periodically (e.g. the number sacks of stabiliser consumed per number of batches produced).

2) Frequency

- frequently and without warning.

3.3.2 Mix

1) Procedure

- visual examination of the homogeneity of the mix;
- timing the average mixing time.

2) Frequency

- weekly or more.

3.4 Waiting time before use

1) Procedure

- timing the average waiting time.

2) Frequency

- weekly or more.

3.5 Curing

1) Procedure

- visual examination (shrinkage cracks, surface drying out);

2) Frequency

- weekly

4 Conditions for taking delivery of earth supplies

4.1 General

4.1.1 Types of check on taking delivery

There are two types of check on taking delivery:

- a simple check, which relates solely to the comparative examination of the appearance, the simplified sedimentation test and the sand equivalent test of the earth supplied compared with the values recorded in the reference earth selected when ordering;
- a complete check, which relates to measuring texture and plasticity and the presence of organic matter and sulphates with the values of the sample of reference earth.

4.1.2 Choosing the type of check on taking delivery

The buyer is free to choose the type of check on taking delivery.

If the buyer requires that a complete check should be carried out, it is preferable for him to inform the supplier of this in writing on the order document.

Carrying out laboratory tests intended to check product conformity to reference values normally requires a minimum of two weeks.

4.1.3 Date and place of taking delivery

Taking delivery occurs at the moment the buyer assumes responsibility for the products, i.e. either at the supplier location or at the delivery location.

If it takes place at the supplier location, the date should be mutually agreed. The buyer should be present or represented.

If it takes place at the delivery location, the date should be indicated to the supplier who has the right to be present at the operations relating to taking delivery, or to be represented there by a person attending on his behalf.

Unless specifically stated, taking delivery can occur at the delivery location only if the supplier is responsible for the transport.

4.2 Taking delivery on site

As soon as the earth has been unloaded and before any subsequent handling in the brickworks, the buyer should proceed with a overall examination of the appearance of the earth.

If this examination shows that the earth delivered is not homogeneous in nature, after due hearing of the parties, one may proceed, at the supplier's expense, to sort it with a view to separating the *a priori* acceptable types of earth from the rest of the delivery.

If the earth is homogeneous in nature, one should proceed with the operations for taking delivery properly speaking.

4.3 Simple check on taking delivery

4.3.1 Samples

For each delivery, take a sample at random and from below the surface of four buckets of earth at four points from the bottom of the pile and two buckets from the upper part of the pile.

Having carried out the simple sedimentation test examination of appearance and that of sand equivalent, these products should be returned to the delivery.

4.3.2 Conditions of acceptability

If the results of the examination give values corresponding to the reference values, the delivery should be accepted.

4.4 Complete check on taking delivery

4.4.1 Examination of appearance

The complete check on taking delivery includes, first, examining appearance as defined above.

Complete checks on taking delivery are carried out in the manner described below.

4.4.2 Samples from the lots

4.4.2.1 Deliveries of up to or equal to 7 tonnes or 5 m³

No sample is taken if the delivery is up to or equal to 7 tonnes or 5 m³ in volume. Consequently, visual examination is sufficient.

4.4.2.2 Deliveries of over 7 tonnes or 5 m³

Split the delivery into lots of maximum 7 tonnes or 5 m³.

4.4.2.3 Particular case of supply occurring on several sites

When delivery is taken on the supplier location, split the complete supply into lots of maximum 21 tonnes or 15 m³.

When delivery is taken on site where it is common to several sites, the reference site is selected by the entrepreneur, who advises the supplier of this in writing.

4.4.2.4 Samples

The samples must be taken on the basis of a sampling process the procedure for which is defined by the standards for testing.

4.4.3 Conditions of acceptability

If, for each of the tests carried out, the results conform to the reference values, the delivery should be accepted.

If this is not the case, one may proceed with a counter-expertise for the test which failed to give satisfaction.

If the results of the counter-expertise are still unfavourable, the delivery can be refused. If the result is favourable, the whole delivery should be accepted.

4.4.4 Choice of laboratory

Tests are carried out on site, in a workshop or in a laboratory selected by mutual agreement between the supplier and the buyer.

4.4.5 Costs of taking delivery

The costs of taking delivery are borne by the buyer if the conditions of acceptability are satisfactory and borne by the supplier if they are not.

4.5 Particular case

The preceding arrangements do not preclude, by mutual consent, the buyer and the supplier proceeding with partial checks, relating only to certain reference values.

5 Annexe

It is recommended that the following technical document be consulted:

- Compressed earth blocks. Vol. II. Manual of design and construction. CRATerre-EAG: Guillaud H., Joffroy T., Odul P. Aus der Arbeit von GATE, Friedrich Vieweg & Sohn, Braunschweig/Wiesbaden, Germany, 1995.

**ARS 682: 1996 - Compressed earth blocks
Code of practice for the assembly of compressed
earth block masonry**

1 General

1.1 Object

This code of practice describes the state of the art relating to the assembly of compressed earth blocks masonry (CEBM), such as it is known in the light of the current state of the technique.

1.2 Field of application

The rules described in the present code are applicable in all construction enterprises operating in the context of public or of private markets.

The standard is not applicable in areas subject to earthquakes, floods or cyclones to an extent that requires the application of appropriate rules in order to avoid major damage.

2 Code of practice

2.1 Laying out

2.1.1 General

It is on the quality of the layout of buildings that ease of assembly partly depends and as a result the quality of the construction, from both a technical and an aesthetic point of view, and this is particularly true for facing masonry.

If a detailed brickwork plan has been prepared, i.e. if the distances (horizontal and vertical) have been defined using the dimensions of the blocks used as well as the thickness of the joints, laying out should scrupulously respect the dimensions indicated on the plans.

If no detailed brickwork plan has been prepared or if the dimensions of the blocks and/or the thickness of the joints differ from what the designer had anticipated, the dimensions given should be modified. Agreement with the architect may be needed. Laying out should be done according to accepted practice using approved and reliable measuring instruments the measurements of which do not vary.

2.1.2 Horizontal laying out

Measuring instruments which enable one to measure directly the greatest lengths of the buildings should be used. Flexible tape measures should preferably be metallic. Right angles should be determined by triangulation (the 3-4-5 rule).

The best technique for laying out is to use site boards firmly fixed into the ground; these enable alignment strings to be stretched from nails or saw cuts. The site boards (at least their upper part) must be placed at the same level, and this should if possible correspond to the first course of CEBM (or to the upper part of the footing), which will enable this first course to be perfectly adjusted and therefore to serve as a reference.

2.1.3 Vertical laying out

The upper level of the site boards (horizontally adjusted) should preferably serve as a reference for the masonry work. Other points can, however, be used, provided they are firmly fixed.

To respect the vertical distances indicated by the brickwork plan, gauge rods should be used. These indicate the levels of courses and of important elements (window sills, lintels, ring beam, height of wall). Gauge rods can be mobile, but should preferably be fixed in strategic points of the building. When the gauge rods are sufficiently rectilinear and rigid, they can serve directly as a support for the strings possibly using strainers, nails or saw cuts. These marks are placed at regular intervals corresponding to the vertical brickwork measurements.

2.2 Scaffolding and safety

2.2.1 Safety on site

Scaffolding should be erected in such a way as to respect safety regulations. It is standard practice to use safety boots and site helmets.

2.2.2 Fixing scaffolding

With facing masonry, fixing scaffolding to the walls should be avoided as this means subsequent patching which is not easy. Scaffolding should therefore preferably be positioned sufficiently far away to avoid it banging against the wall and may be equipped with a system to prevent this occurring.

With rendered masonry, fixing scaffolding to the walls is not a problem. However, using the wall to support the scaffolding should be done only after its capacity to resist specific forces has been checked, and notably with regard to the stresses caused by scaffolding systems resting on the wall.

2.3 Deliveries and on-site stocks

2.3.1 General

Materials should be checked when they are delivered on site as a minimum by visual inspection. Simple field tests can also allow an overall assessment of whether the materials delivered conform.

It is recommended that the same types of check be carried out just before application, in order to separate out materials which might have deteriorated as a result of being badly stocked on site.

2.3.2 Compressed earth blocks

Compressed earth blocks should be unloaded with care. Transporting them on the site should be restricted and if possible done with suitable means of transport with a flat loading base.

Blocks intended for facing masonry should be handled with particular care, to avoid chipping them. One should therefore seek to restrict unnecessary handling by always stocking them as near as possible to where they are to be used. At the same time care should be taken not to overload recently completed scaffolding and floor slabs.

Stocks should be kept in stable piles and on ground which is sufficiently flat and firm and not liable to flooding.

2.3.3 Unstabilised compressed earth blocks

Stocks of unstabilised compressed earth blocks should be protected from rain in order to avoid surface erosion. If the blocks are stocked directly on the ground, good peripheral drainage should be used, to avoid rising damp which could affect the blocks. These measures should be taken only when a risk does exist (e.g. rainy season).

2.3.4 Cement and other binders

These should be stocked sheltered from humidity, or under cover, and raised off the ground on pallets or on any other support which allows good ventilation.

2.3.5 Earth and sand intended for preparing laying mortar

Earth and sand should be stocked on areas which are clean and above all cleared of any vegetation. Earth which is to be sieved should be protected from rain as wet earth is impossible to screen.

2.3.6 Earth intended for preparing stabilised earth mortar

In order to avoid lumps forming and to ensure the homogeneity of the mix, the earth should not be wet. It should therefore be protected from rain and capillary rise.

2.4 Composition, preparation and utilisation of the mortars

2.4.1 General

Bonding between compressed earth blocks is generally achieved using mortars prepared from the same materials as the CEBs, in order to achieve compatibility and similar strengths, i.e.:

- an earth mortar for unstabilised CEBs;
- a stabilised earth mortar for stabilised CEBs.

The earth used should preferably be of the same nature but can be different in origin.

Because no compression occurs, the strength of the mortar obtained is generally lower than that of the CEBs. Moreover, the significant water dosage (approximately 30%) required for the mortar to be easily workable, can result in cracking. The generally rapid drying out of mortar, despite the precautions which should be taken, can result in the stabilisation being less efficient, and this is particularly the case with low dosages.

For example, in the case of cement, correct practice is to adjust the dosage used for CEBs by:

- significantly increasing the proportion of sand to eliminate risks of cracking;
- significantly increasing the dosage of stabiliser, i.e. a proportion of approximately 1.5 to 2 times greater for low dosages (3 to 6%) and of 1.2 to 1.5 times greater for high dosages (7 to 10%).

Cement stabilised compressed earth blocks can also be bonded with sand-based mortars such as the following:

- sand and quicklime or slaked lime mortar (approx. 1 part lime to 4 parts sand);
- sand and hydraulic lime mortar with low dosages (200 to 250 kg/m³);
- quarry sand and cement mortar (250 kg/m³).

Carrying out preliminary tests, in real conditions on site, allows the most suitable composition to be determined.

In certain circumstances, it is acceptable to use unstabilised earth mortar for the masonry of stabilised earth blocks (e.g. well protected walls subject to little stress).

2.4.2 Screening the earth

Earth screened using a 10 mm side square mesh is perfectly suitable. Other sizes, however, can also be suitable, bearing in mind that the maximum grain size passing through the mesh can be adjusted by tilting the mesh.

It is recommended that the screen should be fairly large in size. Dimensions in the order of 2m x 1m (h x w) are perfectly suitable.

2.4.3 Dosages

The materials making up the composition of the mortar should be measured out with precision. Dosage by weight is precise, but difficult to carry out on site without special equipment. Procedures for dosing by volume are therefore the most commonly used. Using spades to measure out is too imprecise, and not acceptable. One can, however, use buckets or wheelbarrows when their volume is known. These volumes should correspond to a whole number of recipients. Filling regularly, by levelling off and using the entire volume of the recipient are essential to obtain a regular dosage.

Using gauge boxes is recommended. These are of predetermined volume and therefore enable the prescribed dosage to be matched with a high degree of precision.

Using the sack (of stabiliser) as a basic unit is valid only if the quantity contained is reliable.

2.4.4 Preparing unstabilised earth mortars

These are prepared by mixing water into the earth. The proportion of water is in the order of 30%, but varies according to the clay content of the earth.

Mixing can be done by hand, in a cement-mixer, or even in a planetary or linear mixer.

Preparation can be done a long time ahead and in large quantities, whether in a dry or a wet state.

As earth absorbs water little by little, mixing is always carried out more liquid than is necessary to achieve the workability required for the assembly of compressed earth blocks.

If the earth has started to set through drying out, more water can be added, and as often as necessary, to recover the required workability.

2.4.5 Preparing earth mortars stabilised with cement or with hydraulic lime

The earth should be loose. If it is not naturally so, or loose on delivery, it should be screened or broken down, even if it contains no grains of too great a size. Loosening the earth is necessary to enable the mixing to take place quickly which ensures the homogeneity of the mix by spreading the stabiliser evenly throughout the mass.

2.4.5.1 Manual mixing

The various components are first mixed dry and then the water is added. To obtain good homogeneity, each mixing operation should not exceed 5 wheelbarrow loads, i.e. approximately 300 litres of mix.

Mixing with water should be carried out only for a quantity of mix which can be used within the following half hour in order to take advantage of the reaction of the cement with the other components of the mortar. To achieve this, mixing with water can be done gradually with small quantities taken from the initial dry mix.

Retempering a mortar which has already taken with water is not permissible as the stabilisation could not occur in good conditions and the strength of the ultimate mortar would be very low (in certain cases even lower than that of an unstabilised earth mortar).

2.4.5.2 Mechanical mixing

Mixing can be done using a planetary or linear mixer or even with a simple concrete-mixer.

With a planetary or linear mixer, mixing takes place as for manual mixing, i.e. first the dry mixing is done, and the water is added later.

With a concrete-mixer, the filling process is reversed: the water is put in first, then the cement is added, followed by the sand (if any) and finally the earth. For the same reasons as stated for manual mixing, the quantities of mortar prepared must be capable of being used within the following half hour and any mortar which has already taken should be rejected.

2.4.6 Preparing earth mortars stabilised with non-hydraulic lime

The mix should be prepared in advance (at least 2 hours before, but preferably one day ahead) and if possible covered so that it stays moist until it is used. This gives the lime time to react properly with the clays, without hardening through carbonatation occurring, as this takes place only in the presence of air.

2.4.7 Preparing earth mortars stabilised with bitumen

Bitumen is used in liquid form (cut-back or emulsion).

Mixing is carried out with earth which has already been mixed with water and is therefore in a liquid state (see preparing unstabilised earth mortars). These mortars can be prepared in advance. However, remixing them once they have dried out is not advisable.

2.5 Executing the masonry work

2.5.1 Bonding patterns

Compressed earth blocks should be used in masonry in accordance with the detailed brickwork plan already drawn up and following a bonding pattern which respects the rules that there should be no superimposed vertical joints and that at least 1/4 of the horizontal surface of the block should be covered.

The most common bonding patterns are those used for traditional masonry work with small elements.

2.5.2 Thickness of the mortar

The most common thickness of mortar is 1.5 cm.

To be able to use all the classic bonding patterns, the dimensions of the block should follow the rule:

$l = 2 \times w + tm$ (l = length, w = width, tm = thickness of the joint).

For fill-in walls with no bonding pattern, it is not necessary to apply this rule.

2.5.3 Wetting the blocks

In order to allow the binder to take, the mortar must be prevented from drying out too quickly. It is therefore vital to wet the blocks and the course on which they will rest before laying them. This should be done by sprinkling using a whitewash brush or by rapidly dipping them in water. Excessive wetting reduces the quality of the masonry work. When using unstabilised CEBs, they should not be wet too much to avoid damaging them. The water should be fully absorbed before laying. The water used should not contain any deleterious matter.

2.5.4 Cutting blocks

Cutting CEBs as they are being used should be carried out using any tool enabling one to obtain a precise cut and a flat surface, e.g. bolsters, saws, disks, etc.

2.5.5 Laying blocks for ordinary masonry intended to be rendered

The blocks should be laid on a full bed of mortar in order to ensure that they adhere well. It is recommended that the vertical joints should be filled at the same time as laying the CEBs, which is faster but above all more efficient than filling in from above after laying.

The joints can be lightly brushed or scratched after laying to allow the render to adhere well.

2.5.6 Laying blocks for facing masonry

The blocks should be laid on a full bed of mortar in order to ensure that they adhere well. It is recommended that the vertical joints should be filled at the same time as laying the CEBs, which is faster but above all more efficient than filling in from above after laying. Using this technique also enables one to obtain a good finish more easily. As the mortar oozes out slightly, one has only to scrape off the surplus holding the trowel at an angle to obtain a well filled and neat joint that can either be left as it stands or finished off later with a special tool.

As a result, the consistency of the mortar is very important. It should not be too liquid as it would drip down the wall during laying; nor should it be too dry as this would make it difficult to squeeze the mortar and thus to obtain a well filled and neat joint. The mortar should therefore not be laid too far in advance on the preceding course.

2.5.7 Laying the first two block courses

The first two courses will serve as a reference for aligning all the subsequent ones. They therefore have to be perfectly aligned (see chapter on laying out). Before proceeding with actually laying these courses, it is preferable to try them out dry in order to check that the dimensions and the bonding pattern correspond properly.

Adjusting the dimensions is acceptable if this allows simple and correct bonding pattern configurations to be used. The thickness of the joints can also be modified without however exceeding ± 5 mm of the thickness planned.

Laying is then done one block at a time which allows the mortar thickness to be respected and avoids running the risk of gradually shifting the bonding pattern along. If the footing is seriously defective in terms of flatness, it will take several courses to retrieve horizontality in order to respect the tolerance of ± 5 mm. To obtain high strength masonry, it is recommended that the corner blocks should be laid using a plumb line and the others using a guide string.

2.5.8 Laying the remaining courses

Each course should be started off in the corners and at the level of wall junctions. Levelling, adjusting to plumb and adjusting the height of the course (see chapter on laying out) should be carried out for each of these blocks before going on to lay the whole course.

The use of vertical gauge rods is strongly recommended for facing masonry. Vertical gauge rods can be mobile or fixed. Laying several levels of blocks in the course before filling in the wall is possible if the mortar sets sufficiently quickly and enables the blocks to be adjusted without shifting the blocks on the lower courses and if the mortar has negligible shrinkage.

The maximum height of masonry work should not exceed 1m per day.

2.5.9 Jointing for facing masonry

Joints (including dry joints) can be simply scraped off with a trowel as described above. If necessary, jointing can be done using a pointing trowel.

Jointing should preferably be done as soon as the mortar starts to set, i.e. within 1/2 an hour to an hour of laying the blocks. The mortar, which has previously been scraped level with a trowel (after jointing if appropriate) is simply pressed in using a tool with a rounded shape (jointer) in such a way as to obtain a finish which is slightly hollow, but which does not retain water.

More hollow joint finishes are possible inside or on walls which are well protected from bad weather, or with CEBs and EMs which are highly resistant to humidity.

2.5.10 Pointing for facing masonry

The laying mortar is scraped to a depth of at least 2 cm. The joint is moistened, and as soon as the water has been fully absorbed, it is refilled with fresh mortar treated in the same way as described above. This technique, which is especially useful for thick masonry, allows a water-resistant mortar to be used on the façade and a more weakly dosed mortar for the inside of the wall.

2.5.11 Protecting freshly erected masonry and cleaning

In hot, dry weather and if the walls are built with an earth mortar stabilised with a hydraulic binder, it is advisable to protect the walls from direct exposure to the sun and to spray them lightly and at regular intervals in order to prevent them from drying out too quickly, so that the binder can take correctly.

Walls erected using a non-hydraulic binder (lime) should not be moistened; on the contrary, for one month after laying, they should be protected from the direct effects of bad weather.

Drips or dirty marks should be cleaned off the masonry as soon as it is finished using non-abrasive tools (e.g. a sponge or a soft brush, etc.)

Subsequently, masonry should be protected from blows to avoid any risk of chipping or other damage.

2.6 Bonding with the other construction components

2.6.1 Water proofing from ground humidity

Footings are subject to capillary water rise from surrounding ground which is (even temporarily) wet, when the materials used for their construction are permeable. This phenomenon will be accentuated if the evaporation capacity of the footing is poor either because it is low or because it has a water proof render.

If this is the case, special technical measures should be used. There are several possible solutions:

- very good surface drainage around the building;
- the footing is built up sufficiently high and has a surface which encourages hydric exchanges, allowing water to evaporate before it reaches the CEB wall;
- the CEBs used have properties of sufficient wet compressive strength and are capable of resisting alternate dry-wet cycles;
- a capillary barrier (a layer of sufficiently dosed mortar, bituminous felt, etc.) is interposed between the footing and the wall;
- a cement slab is interposed between the footing and the wall. In this event, the slab itself should be protected from capillary rise.

2.6.2 Window sills

The use of window sills is highly recommended.

Window sills can be integrated into the fixed frame of the wood or metalwork, poured *in situ* or prefabricated. In the latter case, they should be laid on a bed of mortar.

Except where otherwise prescribed, window sills should jut out from the bare façade by at least 6 cm and should be fitted with a throat.

2.6.3 Fixing doors and windows

In the absence of technical specifications proper to the project, fixing doors and windows will be carried out according to the following prescriptions.

1) Placing openings during wall construction

Wood or metalwork openings (or at least their pre-frame which will be made rigid) should be put into place and braced. If the prefabricated frames are made of wood, they must be perfectly dry so that they do not move once they are in position. The bond with the wall is achieved using fixing anchors (for metalwork) or 100 mm nails (for woodwork) spaced so that there is a fixing point approximately every 5 courses.

The spacing of the fixing anchors should be planned in such a way that they correspond to the location of a joint so that they are set into the mortar. Nails should be located between two courses of blocks, before the next course is laid. The mortar used at the level of the fixing points can be stronger than the usual mortar if the latter is considered to be too weak.

2) Placing prefabricated elements after construction

Special elements should have dimensions corresponding either to whole blocks, or to half-blocks, so that they can be positioned in the walls. These blocks can be made of poured concrete in which a fixing anchor has been positioned, or alternatively they can be pre-treated wooden blocks.

3) Placing openings after construction by fixing

There should be at least 4 fixing points for windows and 6 fixing points for doors.

In thick walls, the fixing is achieved by digging a hole shaped like a fish-tail and leaving a gap of at least 5 cm around the fixing anchor. It is recommended that the bond between the wall and the mortar be improved by hammering 100 mm nails in all around the hole. The fixing mortar should preferably be a sand-cement mortar dosed to 300 kg/m³ and should be applied with a minimum of water in order to avoid shrinkage.

In thin walls, half-blocks located on either side of the metal or woodwork should be removed. The spaces thus liberated should then be dealt with in the same way as described in the previous point. Using a formwork is however necessary to ensure that the hole is well filled. In the case of metal or woodwork which is subject to little stress, as in the case of «Naco» louvre window systems, the same procedure can be used by digging only the thickness of the joint and therefore refilling it after the metal or woodwork is in position. This procedure however requires the fixing anchors to be well positioned at the height of the joints.

2.6.4 Beams and lintels

Wooden beams and lintels should be placed on a bed of mortar. The same applies to prefabricated concrete beams or lintels. Before putting them into position, one should check that these elements are dry and that their shrinkage is complete. In the case of concrete beams or lintels poured *in situ*, the pouring should be done as little liquid as possible in order to avoid to the maximum extent the tensions caused by shrinkage which could cause the walls to crack. In the case of buildings with facing masonry, using a fairly dry bed of mortar on the edges of the formwork is indispensable to fill in inevitable gaps and thus avoid dripping onto the masonry which would be very difficult to clean off subsequently.

2.6.5 Ring beams

Using wooden horizontal ring beams is possible, but the wood should be dry and pre-treated against fungi and insects. The bond between the wall and the ring beam is achieved by using 40 mm nails in all the joints. Wooden ring beams are placed on a bed of mortar.

Reinforced concrete can be used for ring beams. However, the section of concrete ring beams should be minimal so that the forces transmitted during the drying out of the concrete are not too great, thus avoiding the danger of cracking in the walls or even destabilising the structure.

The concrete used should be sufficiently firm in order to avoid too much shrinkage which could lead to cracking in the walls. For buildings with facing masonry, using a fairly dry bed of mortar on the edges of the formwork is indispensable to fill in inevitable gaps and thus avoid dripping onto the masonry which would be very difficult to clean off subsequently.

Using special compressed earth blocks is particularly recommended as this avoids all of the problems described above. Vertical reinforcement should preferably be replaced by simply using thicker masonry.

2.6.6 Tying down the roof

Common roofs should be built according the state of the art relative to building construction.

So-called light roofs should be anchored to the masonry in order to avoid the possibility of being ripped off by the wind. In medium risk circumstances, it is recommended that anchoring should be done over a height of blocks of at least 40 cm. If possible, the anchoring should be fixed on or under the ring beam.

2.7 Stabilised renders (earth-sand-cement/lime and sand-cement/lime)

Renders on compressed earth block walls should be applied following the usual rules, proper to each type of render. Nevertheless it is advisable to avoid renders which are too thick (maximum 2 cm) and single coat covering products in the case of sand-cement/lime renders. It is also appropriate to apply the following recommendations.

1) Preparing the key

The key should be well prepared by lightly brushing the joints to hollow them out to a depth of no more than 2 cm, and by brushing the surface of the blocks if it is too smooth.

2) Wetting the wall

The wall must be particularly well wet, and several times, before applying the render, especially if it is to be applied in dry weather.

3) Sand-cement and sand-hydraulic lime renders

These often fairly rigid renders have a tendency to come away from the walls. To ensure that they stick well over time, it is appropriate to:

- carefully check the efficacy of the capillary barrier chosen;
- on stabilised CEB walls, not to use cement dosages which are too high: maximum 250 kg/m³ or 300 kg/m³;
- on non-stabilised CEB walls, to place a mesh of steel wire (if possible galvanised) stretched between nails regularly spaced over a square or triangular screen with 30 cm sides. One wire should always be stretched at the level of the edges in the corners of the wall and the window ledges.

This mesh will be fixed between the two (first) coats of render which should be applied at minimum one day's interval and if possible two days' interval.

2.8 Paints, washes and waterproofing products

Applying paints and washes should be carried out according to the known rules proper to each product. However, the following rules should be applied:

1) Preparing the key

The walls should be dust-free. Any blocks which are too smooth should be brushed beforehand to obtain a rough surface providing a good key.

2) Wetting

This is necessary only for cement based washes and should be done thoroughly, and several times.

3) Thickness

The thickness of coats of paint and washes should be minimal. Preliminary tests should be carried out to determine the ideal mix enabling sufficient coverage with the minimal thickness.

4) Preparing earth-cement washes

This type of wash is highly suitable for obtaining a finish which is neat, durable and reliable, at a very low cost. The use of white cement and colouring agents enables one to achieve very high quality finishings.

The earth should be mixed with water until a very liquid wash is obtained. This mix is left to rest for approximately 2 minutes so that the largest sand particles settle. The resulting wash is transferred into another container and mixed with half its volume in cement, if necessary with an added colouring agent. The resulting mix should be vigorously stirred from time to time and used within two hours.

Small colour differences may occur between different preparations. Sufficient quantities must therefore be prepared to cover complete wall panels.

5) Waterproof paints or washes and waterproofing products

Products which form a waterproof coat can be efficient but are extremely dangerous as they prevent water from moving from the inside towards the outside of the wall. If such movement occurs, they can blister or fall off, but more seriously, they can cause problems due to stagnant humidity in the walls. As a result, such products are usable only if adequate measures are taken to avoid any water infiltration in the walls: capillary barriers, protecting the wall at plinth level, good ventilation in the rooms, especially rooms with water (bathroom, WC, kitchen, etc.) It is also recommended to use such products only on walls which behave well in the presence of moisture.

3 Checking procedures

3.1 Laying out

Check that the dimensions given on the plans have been respected.

Check the suitability of the proposed bonding pattern.

If necessary, modify the dimensions indicated on the plans to be able to use simple bonding patterns.

Check that the footing has been levelled.

Beforehand check the gauge rods used by the different builders.

3.2 Scaffolding

Check that safety standards are being respected.

Check that the scaffolding is not banging against the walls (only for facing masonry).

3.3 Deliveries and stocking CEBs on site

Monitor the care taken when unloading and transporting CEBs using suitable means (flat support bed).

Monitor stocking and identification procedures.

3.4 Storage of cement and/or lime

Check that the sacks are carefully stocked sheltered from humidity, or covered and raised off the ground on pallets or on any other support allowing good ventilation.

There must be visual verification with a fine mesh screen (1 mm) that the cement and/or lime contains no tiny lumps which would prove that it had already gone off when accidentally wet.

3.5 Storage of earth and sand for the preparation of the mortar

Check that the earth and the sand are stocked on clean areas, are free of organic matter, and are well protected (rainy season) from water and humidity.

3.6 Screening the earth

Check that the screening operation eliminates any particles larger than those tolerated.

Check that the screen is sufficiently large and is not damaged to avoid projecting larger particles.

3.7 Dosage

Check the accuracy of the dosage used after the mortar has dried out (if possible by conducting preliminary tests): cracking, resistance to brushing, resistance to water, or other laboratory tests.

Check the volume of the recipient used.

Verify the procedures for levelling off raw materials when filling measuring recipients.

Verify the daily consumption of materials per m² actually built. This means knowing the outputs obtained for each type of wall or block.

3.8 Preparing cement stabilised earth mortars

Verify the homogeneity of the mix. It should contain no foreign bodies. It should contain no lumps (due to poor screening).

Check that the water content is correct (plasticity).

Verify that the wet mix is used within maximum 1/2 hour and if possible within less than 1/4 hour.

3.9 Laying the blocks

Check the correct practice, wetting the course and the block before laying, using the mortar within the correct time limits, laying on a full bed of mortar.

Verify that the quality of the mortar (presence and % of large particles) enables a good finish to be achieved.

Check the bonding pattern and the thickness of the joints; check that heights are being respected (use of gauge rods); check that the verticality and the horizontality of the courses and their reclitude (or curvature) are being respected, taking account of tolerances.

Check any cracking of the mortar.

Check that work is being carried out cleanly.

In dry periods, check that the walls are being regularly moistened for a week after construction.

3.10 Window sills and parapets

Check that they are correctly positioned and enable water run-off to occur correctly.

3.11 Ring beam and lintels

Verify the bed surface and the laying on a bed of mortar.

With regard to reinforced concrete, if pouring is done *in situ*, before this occurs check that the formwork is correctly positioned or that some measure has been taken to avoid the concrete running down the wall.

Verify the plasticity of the concrete (if it is too liquid, its shrinkage could pull on the masonry and cause cracking).

3.12 Typing down roofs

Verify the tension of the fixing points and that a very strong protection between the roof structure and the top of the wall has been used.

3.13 Fixing doors and windows

Check that the specifications have been followed.

Check that the number of fixing points conforms to the instructions and that it is sufficient.

3.14 Renders

Check that the key has been properly prepared: by brushing, wetting, and if necessary correct fixing of a mesh.

Check that execution has followed the prescriptions and that drying conditions are good.

3.15 Finishing

Check the final cleaning of the walls (gentle brushing, dusting off).

3.16 Washes

Check walls have been wet beforehand.

Check dosage and correct execution (thickness, homogeneity of colour).

4 Annexe

It is recommended that the following technical document be consulted:

— Compressed earth blocks. Vol. II. Manual of design and construction. CRATerre-EAG: Guillaud H., Joffroy T., Odul P. Aus der Arbeit von GATE, Friedrich Vieweg & Sohn, Braunschweig/Wiesbaden, Germany, 1995.

TESTING AND CONTROL STANDARDS

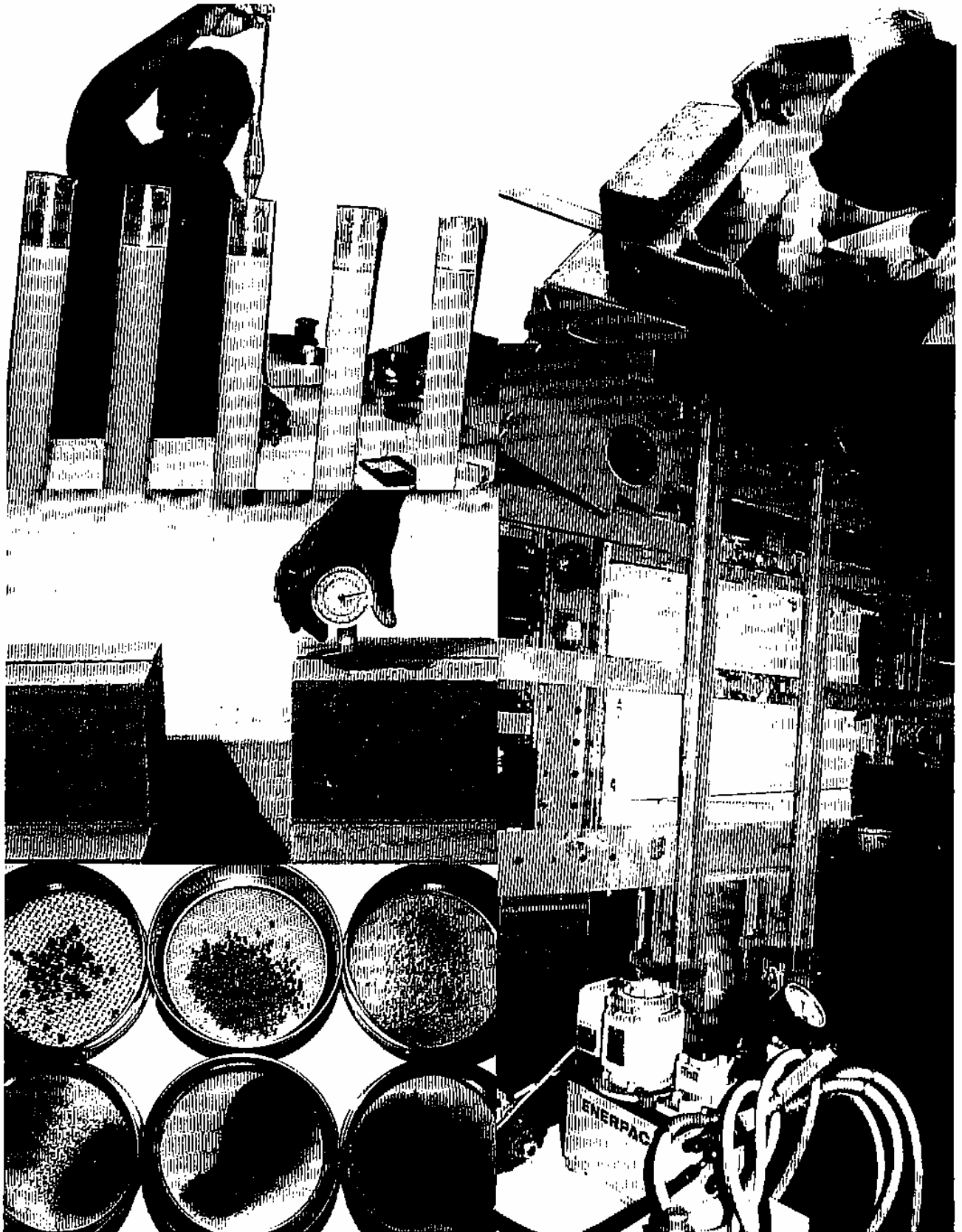

There are two kinds of identification tests for raw materials, and more specifically for earth: quantitative and qualitative.

In the case of the former, tests are carried out using laboratory equipment and the operating modes are those habitually used. In the case of the latter, these are so-called field tests, the use of which certainly figures in the technical literature, but which nevertheless requires a sure level of skill and knowledge on the part of the operator. In all cases, professional experience will be vital.

With regard to mechanical tests, these should be suited to the intrinsic characteristics of earth, which differ widely from those of most other mineral building materials.

**ARS 683: 1996 - Compressed earth blocks
Standard for classification of material identification
tests and mechanical tests**

1 General

1.1 Object

The aim of the present document is to enumerate the tests required to determine the characteristics specified in all of the standards relating to compressed earth block technology, to determine their nature (quantitative and qualitative), the place where they are carried out (at the quarry, in the workshop, on site or in a laboratory) and their character (optional or recommended) and to give indications relating to sources of information on their modes of operation.

1.2 Field of application

These tests are applicable to the material, equipment, elements and components of compressed earth block technology.

1.3 Sources of information

The following documents provide detailed modes of operation which can be used for the execution of the tests. They are referenced by number in the tables which follow.

1. National, regional or international standards habitually used.
2. Compressed earth blocks. Vol. I. Manual of production. CRATerre-EAG: Rigassi V., Aus der Arbeit von GATE, Friedrich Vieweg & Sohn, Braunschweig/Wiesbaden, Germany, 1995.
3. Earth Construction: a comprehensive guide. CRATerre-EAG : H. Houben and H. Guillaud. IT Publications, Rugby, United Kingdom, 1994.
4. Compressed earth blocks: materials identification tests and mechanical tests. ENTPE/CRATerre-EAG, Lyon, France, 1998.

2.2 Tables of tests

Table 1 — Earth tests

Characteristics	Symbols	Tests	Nature of tests	Place of testing			Character of test		Ref. of code of practice
				Quarry	Workshop/Site	Laboratory	Optional	Recommended	
GRANULARITY Texture		- Wet sieving - Hydrometer test - Simplified sedimentation - Sand equivalent - Visual examination - Hand-washing test - Pellet test - Cigar test - Visual examination - Sieving	N N L L L L L L L L L N			x x		x x x x	1,4 1,4 1,3,4 1,4 1,3,4 1,3,4 1,3,4 1,3,4 1,3,4 1,3,4 1,3,4 1,3,4
				x x x x x x x x x x					
Pulverisation ratio			L					x x x	1,3,4 1,3,4 1,3,4
PLASTICITY									
Liquid limit	LL	- Casagrande test	N			x		x	1,3,4
Plastic limit	PL	- Atterberg thread test	N			x		x	1,3,4
Plasticity index	p	- Cone - Calculation	N N			x x		x	1,3,4
CLASS									
Class of soil		- Determined in table	L				x		3
SHRINKAGE									
Linear shrinkage		- Alcock test - Pollat test	N L			x x		x	2,3 1,3,4
CHEMICAL COMPOSITION									
pH		- pH test	N			x			1,3,4
Soluble salts		- Chemical analysis	N						1,4
Acid salts		- Chemical analysis	N						1,4
Alkaline salts		- Chemical analysis	N						1,4
Organic matter or humus		- Chemical analysis - Smell test	N L						1,4 3,4
Carbonates		- Chemical analysis	N						1,4
Sulphates		- Chemical analysis	N						1,4
Chlorides		- Chemical analysis	N						1,4
MINERALOGY									
Methylene blue value of the 0/2 fraction of the soil	VBS (0/2)	- Methylene blue test	N						1,4
Methylene blue value of the entire soil	VBS Total	- Methylene blue test	N						1,4
Nature of colloids		- X-ray test	N					x	1
COMPACTIBILITY									
Optimal water content	Wopt	- Static Proctor - Dropping ball test	N L						4 2,4

L — qualitative N — quantitative

Table 2 — Water tests

Characteristics	Symbols	Tests	Nature of tests	Place of testing			Character of test		Ref. of code of practice
				Quarry	Workshop/Site	Laboratory	Optional	Recommended	
QUALITY Transparency Salinity		<ul style="list-style-type: none"> - Visual examination - Taste examination - Evaporation 	L L L		x x x			x x x	2,3,4 2,3,4 2,3,4

L = qualitative N = quantitative

Table 3 — Cement tests

Characteristics	Symbols	Tests	Nature of tests	Place of testing			Character of test		Ref. of code of practice
				Quarry	Workshop/Site	Laboratory	Optional	Recommended	
QUALITY Class Going off		<ul style="list-style-type: none"> - Rod test - Bending rod - Visual and tactile examination 	N L L		x x	x		x x x	1 2 4

L = qualitative N = quantitative

Table 4 — Lime tests

Characteristics	Symbols	Tests	Nature of tests	Place of testing			Character of test		Ref. of code of practice
				Quarry	Workshop/Site	Laboratory	Optional	Recommended	
COMPOSITION Active lime QUALITY Going off		<ul style="list-style-type: none"> - Chemical analysis - Visual and tactile examination 	N L			x		x	1 4

L = qualitative N = quantitative

Table 5 — CEB tests

Characteristics	Symbols	Tests	Nature of tests	Place of testing			Character of test		Ref. of code of practice
				Quarry	Workshop/Site	Laboratory	Optional	Recommended	
CONFIGURATION									
Sections		- Metric measurement	N		x			x	4
DIMENSIONS									
Work dimensions		- Metric measurement	N		x			x	4
GEOMETRY									
Parallelism		- Metric measurement	N		x			x	4
Surface smoothness		- Metric measurement	N		x			x	4
Edgo smoothness		- Metric measurement	N		x			x	4
Surface obliquity		- Metric measurement	N		x			x	4
APPEARANCE									
Pitting		- Metric examination	N		x			x	4
Roughness		- Visual examination	L		x			x	4
Chips		- Metric measurement	N		x			x	4
Flaking, etc.		- Visual examination	L		x			x	4
Splits, etc.		- Metric measurement	N		x			x	4
Colour		- Visual examination	L		x			x	4
Structure		- Visual examination	L		x			x	4
Texture		- Visual examination	L		x			x	4
PHYSICOCHEMICAL									
Pitting		- Visual examination	L		x			x	4
Efflorescence		- Visual examination	L		x			x	4
MECHANICAL, PHYSICAL AND HYDRIC									
Dry compressive strength	f_b dry	- Crushing strength test	N			x			1,4
Wet compressive strength	f_b wet	- Crushing strength test	N			x			1,4
Dry tensile strength	f_t dry	- Tensile strength test	N			x			1,4
Wet tensile strength	f_t wet	- Tensile strength test	N			x			1,4
Bending strength		- Block breaking test	N		x			x	2,3,4
Dry density	γ_d	- Metric measurement + weight measurement	N		x			x	1,2,3,4
Erosion		- Erosion	N			x		x	4
Abrasion - loss of material		- Abrasion	N			x		x	4
Shrinkage		- Shrinkage	N			x			4
Water absorption		- Weight measurement	N		x			x	4
Water absorption by the exposed face		- Weight measurement	N			x		x	4
Specific heat	C	- Specific heat	N			x			1
Thermal conduction coefficient	λ	- Thermal conduction	N			x		x	1

L = qualitative N = quantitative

Table 6 — Mortar tests

Characteristics	Symbols	Tests	Nature of tests	Place of testing			Character of test		Ref. of code of practice
				Quarry	Workshop/Site	Laboratory	Optional	Recommended	
MECHANICAL, PHYSICAL AND HYDRIC Dry compressive strength Dry tensile strength	f_m dry f_m^t dry	– Crushing strength test – Tensile strength test	N N			x x			4 4

L = qualitative N = quantitative

Table 7 — Masonry tests

Characteristics	Symbols	Tests	Nature of tests	Place of testing			Character of test		Ref. of code of practice
				Quarry	Workshop/Site	Laboratory	Optional	Recommended	
CONFIGURATION Bonding pattern Horizontality of courses		– Visual examination	L		x			x	2,4 4
		– Metric measurement	N		x			x	
DIMENSIONS Execution dimensions		– Metric measurement	N		x			x	4
GEOMETRY Sweep Plumb		– Metric measurement	N		x			x	4
		– Metric measurement	N		x			x	4
APPEARANCE Oozing Macrocracks Chips Colour Texture		– Visual examination	L		x			x	4
		– Visual examination	L		x			x	4
		– Visual examination and metric measurement	L		x			x	4
		– Visual examination	L		x			x	4
		– Visual examination	L		x			x	4
PHYSICO-CHEMICAL Pitting Efflorescence		– Visual examination	L		x			x	4
		– Visual examination	L		x			x	4
MECHANICAL, PHYSICAL AND HYDRIC Dry characteristic compressive strength Thermal heat loss coefficient Thermal lag coefficient Acoustic absorption coefficient Fire resistance Shrinkage	f _k	– Calculated	N			x			4
		– Calculated	N			x		x	1
	δ	– Calculated	N			x		x	1
		– Calculated	N			x		x	1
	I	– Fire resistance	N			x		x	1
	– Metric measurement	N			x		x	1,4	

L = qualitative N = quantitative

USEFUL PROMOTIONAL MATERIAL AND DOCUMENTS

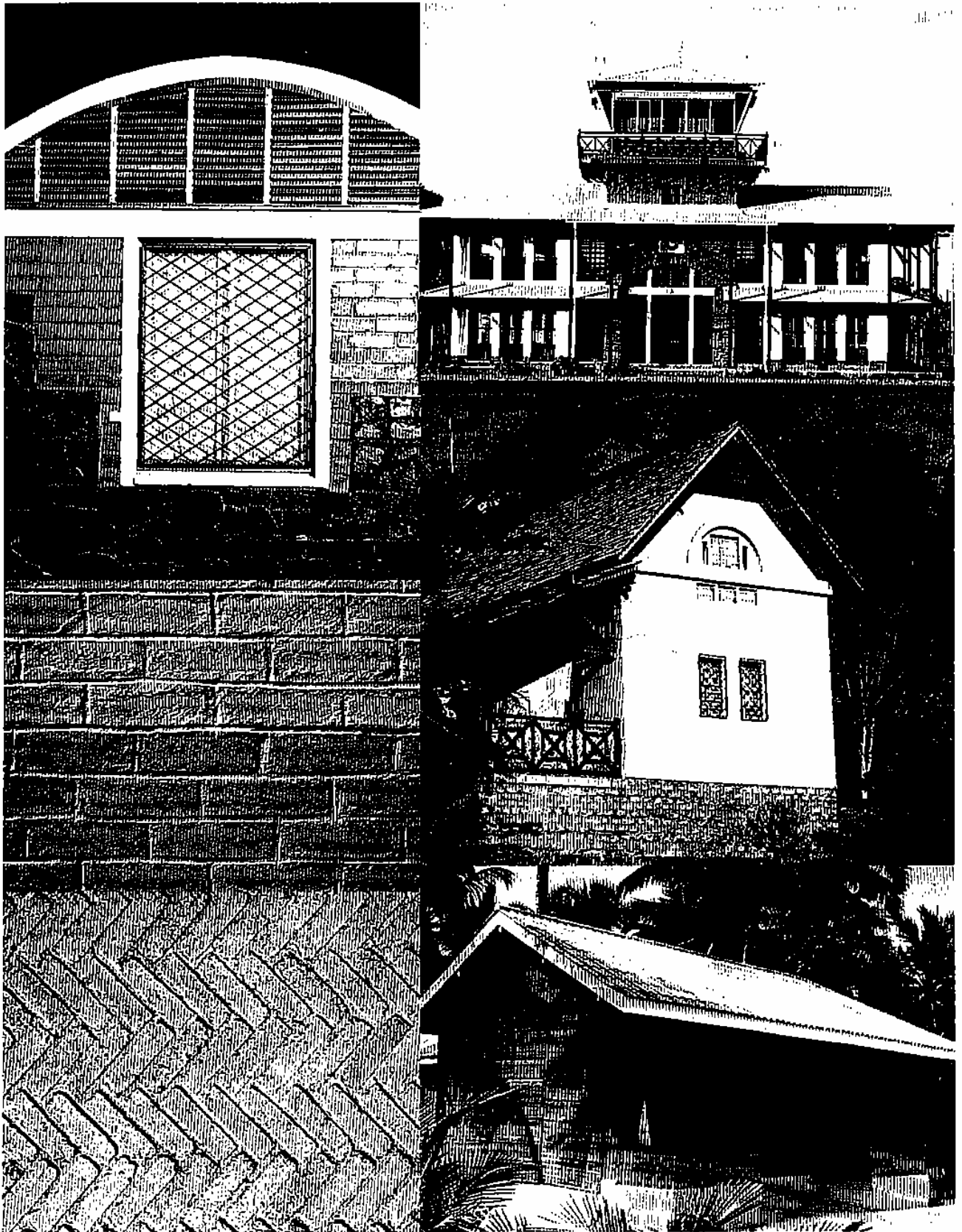

Standards cannot contain all the technical factors which are specific to compressed earth block technology. These technical factors are to be found in technical and scientific works and the complementary use of these is recommended.

The chapter which follows presents and describes the main aids operators need.

Promotional material

The following material has been specially prepared to promote compressed earth block technology amongst all who are involved in the building sector: governments, clients, national standards bodies, chambers of commerce, funders, technical endorsement companies, insurers, scientific and technical centres, laboratories, architectural and engineering practices, commercial enterprises, etc. It enables the impressive performances of the contemporary technology to be visualised in an eye-catching way.



EXHIBITION

Building with compressed earth blocks
CRATerre-EAG: Rigassi, V.
CDI, Brussels, Belgium, 1995.
110 x 75 cm. Colour, 23 panels.

This exhibition's large, exceptionally fine colour photographs and its concise, precise texts cover all aspects of the technology and give a spectacular demonstration of the contemporary performances of this material. It has already been shown on the occasion of industrial working seminars and international meetings in such cities as Lusaka, Libreville, Yaoundé, Brussels, Frankfurt, Grenoble, Bordeaux, etc.

The touring of the exhibition is organised by the CDI and CRATerre-EAG.

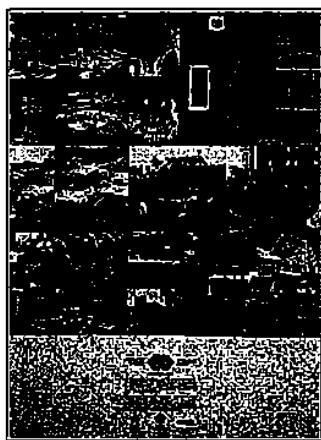

POSTER

Industrialised compressed earth block technology
70 x 100 cm. Colour.

This poster, which was specially prepared on the occasion of the CDI seminar held in Yaoundé in April 1996 on the standardisation of compressed earth blocks, dramatically illustrates the current state of the art of compressed earth block production and industrial construction. It is aimed at all who are involved in the building industry.

Distributed by the CDI and CRATerre-EAG.

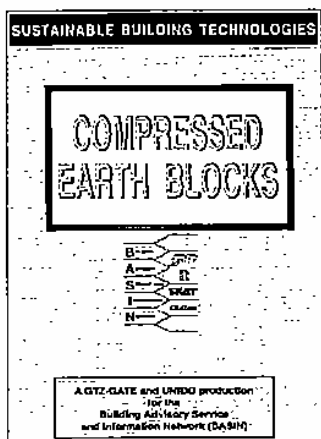

VIDEO

Compressed earth blocks
CRATerre-EAG, GTZ-GATE, UNIDO, DesignWrite Productions.
CRATerre-EAG, Grenoble, France, 1994.
VHS-PAL, 24 min, colour.

This video gives an overview of compressed earth block technology. After first placing earth once more in the historical context of architecture, this documentary shows uses of CEBs which are suited to modern building requirements, a range of different production machines, and examples of the current use of compressed earth blocks in various parts of the world.

Distributed by CRATerre-EAG/BASIN.

Technical documents

The following documents have been specially prepared so that together they form a coherent ensemble, enabling all the main stages of compressed earth block production, design and construction to be thoroughly understood.

EQUIPMENT

Compressed earth blocks : production equipment

CDI Guide, "Technologies series" N°5
CRATerre: Houben H., Rigassi V., Garnier P.
CDI, Brussels, Belgium, 1996
210 x 297 mm, 149 pages, graph., ill., tab., bibl.
ISBN 2-906901-13-X

This guide, published by the CDI in its "Technologies series", is now in its third edition. It presents a complete and detailed inventory of compressed earth block production equipment manufactured and marketed in ACP and EU countries. It also contains selection criteria as well as technico-economic factors. The guide is an irreplaceable aid to decision-making on investment.

Distributed by the CDI and CRATerre-EAG.

BASIC INFORMATION

The basics of compressed earth blocks

CRATerre: d'Ornano S.
Aus der Arbeit von GATE, GTZ, Eschborn, Germany, 1991.
210 x 297 mm, 28 pages, ill.

This booklet lists advantages and constraints, briefly describes the production process and gives indications on the general approach operators wishing to launch an activity in the field of compressed earth blocks should follow; it also addresses some basic economic aspects.

Distributed by CRATerre-EAG/BASIN.

PRODUCTION

Compressed earth blocks. Vol.1 : manual of production

CRATerre-EAG : Rigassi V.
Aus der Arbeit von GATE, Friedrich Vieweg & Sohn, Braunschweig/Wiesbaden, Germany, 1995.
210 x 297 mm, 104 pages, graph., ill., tab., bibl.
ISBN 3-528-02079-2

This manual provides decision-makers, designers, brick manufacturers and building entrepreneurs with the information they need on compressed earth block production. It is designed to enable an overall understanding of a production unit, as an aid to financial planning, and to help with the technical mastery of all stages of production.

Distributed by CRATerre-EAG/BASIN.

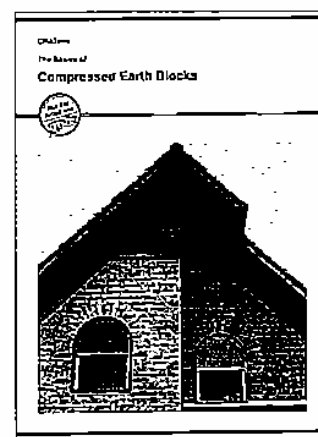
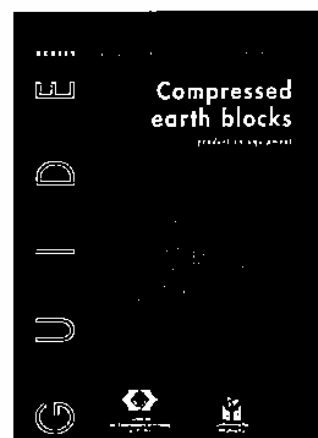

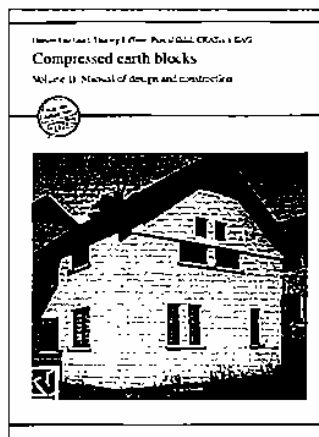

DESIGN AND CONSTRUCTION

Compressed earth blocks . Vol. 2 : manual of design and construction

CRATerre-EAG : Guillaud H., Joffroy Th., Odul P.

Aus der Arbeit von GATE, Friedrich Vieweg & Sohn, Braunschweig/Wiesbaden, Germany, 1995.

210 x 297 mm, 148 pages, graph., ill., tab., bibl.

ISBN 3-528-02079-6

This manual covers all theoretical and practical aspects of design and construction. A large part of the document is devoted to practical, finished examples. It provides answers to all the factual questions which field practitioners ask themselves, be they land use planners, architects, engineers, entrepreneurs or builders.

Distributed by CRATerre-EAG/BASIN.

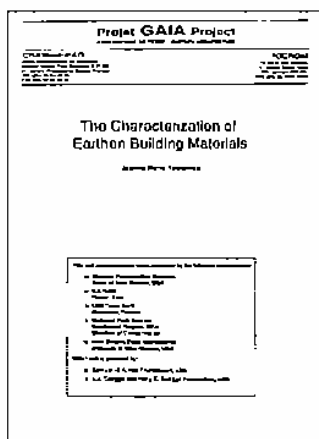

TESTS

The characterization of earthen building materials

Teutonico J.M.

Historic Preservation Division, ICCROM, CRATerre-EAG, GAIA Project, National Park Service, New Mexico State Monuments, Museum of New Mexico, Santa Fe/Rome/Villefontaine, United States/Italy/France, 1994.

VHS-PAL or SECAM, 60 min., colour.

This video shows laboratory tests on earth as a building material. The video is accompanied by a booklet that gives a detailed technical description of all the testing procedures, as well as all the diagrams, graphs and tables necessary for the successful execution of the tests.

Distributed by CRATerre-EAG.

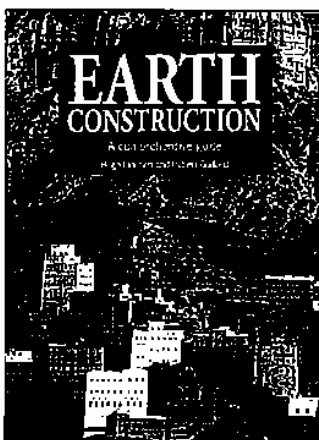

SCIENCE AND TECHNOLOGY

Earth construction: a comprehensive guide

CRATerre-EAG: Houben H. and Guillaud H.

IT Publications, London, United Kingdom, 1994

175 x 250 mm, 372 pages, graph., ill., tab., bibl.

ISBN 1-85339193-X

In the nature of an encyclopaedia, this book covers all aspects of contemporary earth construction technology. Each chapter summarises the most recent work on the subject. An indispensable aid for technicians, engineers and architects interested in or working in the field of earth construction.

Distributed by bookstores and CRATerre-EAG.

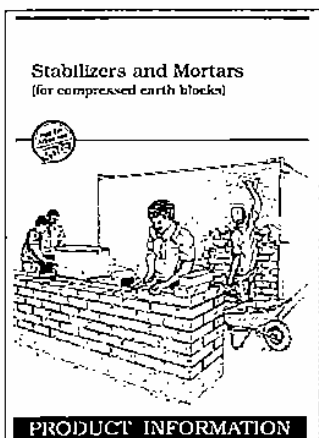

PRODUCTS

Stabilisers and mortars (for compressed earth blocks)

CRATerre-EAG and Mukerji, K.

In: Product information

Aus der Arbeit von GATE, GTZ, Eschborn, Germany, 1994.

210 x 297 mm, 20 pages, graph., tab.

This document explains the principles of stabilisation and describes the different types and characteristics of mortars used in earth block construction. It contains 7 data sheets on products used for stabilisation, mortars, plasters and renders: natural products, lime, Portland cement, gypsum, bitumen, synthetic products, specialised commercial products.

Distributed by CRATerre-EAG/BASIN.

OFFERS OF SERVICE



Introducing compressed earth block technology into an enterprise presupposes that equipment and skills have been acquired.

This technology transfer must be carefully considered and organised in a suitable and professional manner.

In order for this transformation to take place in the best possible conditions, a certain number of services are available to operators wishing to take the precautions necessary to ensure the success of their initiative.



CENTRE FOR THE DEVELOPMENT OF INDUSTRY

A TOOL FOR THE DEVELOPMENT OF INDUSTRIAL ENTERPRISES IN ACP COUNTRIES

The Centre for the Development of Industry (CDI) is an ACP-EU institution financed by the European Development Fund (EDF) under the Lomé Convention bringing together the European Union and the 70 ACP countries (Africa, Caribbean and the Pacific). Its objective is to encourage and support the creation, expansion and restructuring of industrial companies (mainly in manufacturing and agro-industry) in the ACP countries. To this effect, it promotes partnerships between ACP and European companies which may take various forms: financial, technical or commercial partnership, management contracts, licensing or franchise agreements, subcontracts, etc.

The CDI's services are easily accessible and are subdivided into 4 facilities (see table) to support the different stages in the creation, expansion and rehabilitation of industrial companies. In this framework, the CDI intervenes free of charge by providing its own expertise or making a non-reimbursable financial contribution. The CDI does not finance the investment of the project but helps to seek out and put together a financing package.

The requests for assistance submitted to the CDI are evaluated on the basis of the financial and technical viability of the projects and their contribution as regards the development of the country concerned. All dossiers submitted to the CDI are treated confidentially. The total amount invested in these projects, or the value of the assets in the case of existing companies, must normally be between ECU 200,000 and ECU 10 million. Smaller companies may be accepted in certain cases: pilot projects, grouping together of several companies with a view to joint assistance, priority industrial sectors, etc.

By „project“, the CDI means an industrial unit or group of units in the process of being created or undergoing expansion, diversification, rehabilitation or privatisation.

CENTRE FOR THE DEVELOPMENT OF INDUSTRY (ACP-EU LOME CONVENTION)

Avenue Hermann Debroux 52, B-1160 Brussels, Belgium

Tel.: +32 2 679 18 11 - Fax: +32 2 675 26 03

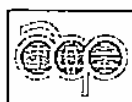

ACP Group



European Union

**FACILITIES WITH A VIEW TO THE CREATION,
EXPANSION, DIVERSIFICATION, REHABILITATION AND
PRIVATISATION OF INDUSTRIAL ENTERPRISES**

	FACILITY 1	FACILITY 2	FACILITY 3	FACILITY 4
TYPE OF OPERATION	Identification of company projects and potential partners (Preliminary studies by country or by sector, interfirm meeting)	Operation prior to implementation of the project (Search for partners, assistance in 1st contact, feasibility studies, market surveys, diagnoses, expertise)	Mounting the project (Assistance in assembling the financial and legal package, search for financing and support in contacts with finance institutions)	Project start-up and development (Help in setting up the project, technical and start-up assistance, assistance in training, management and marketing)
BENEFICIARIES	Development, promotion and finance institutions	Promoters and/or companies in an ACP country or an European Union member country wishing to become involved individually or jointly in an industrial project in an ACP country		
TYPE OF CONTRIBUTION	Advice, technical assistance or subsidy			
AMOUNT	Case by case	Max. ECU 150,000 per project per year (The aggregate amount of all contributions to the same project/company must not exceed ECU 300,000 and must be less than 20% of the total investment, except in the case of pilot projects.)		
LIMITS TO THE CDI CONTRIBUTION	Maximum 50% of the total cost	Maximum 2/3 of the total cost (Beneficiary promoters/companies must contribute at least one third of the cost.)		
WHERE TO SUBMIT YOUR REQUEST	Applicants may approach the CDI directly or contact one of the correspondents in the CDI's ACP network or one of the member institutions of the CDI's European Union network, a list of which is available on request			
PRESENTATION OF THE REQUEST	Companies and promoters must clearly define the assistance that they require from the CDI. A brochure entitled „How to benefit from the CDI facilities“ is also available on request. This describes in detail the way in which to present dossiers requesting assistance, a summary of which is given below.			

SUBSTANCE OF THE REQUEST

In general, the information to be provided is as follows:

<p><u>FACILITY 1:</u> Identification of industrial projects and potential partnerships</p> <ul style="list-style-type: none"> • description of the organisation putting forward the proposal and, if applicable, the companies on whose behalf this identification process is being conducted, • description of the proposed activity, • detailed timetable for execution of the specific operations, • detailed budget proposal. 	<p><u>FACILITY 3:</u> Mounting the project</p> <ul style="list-style-type: none"> • description of the existing company and/or investment envisaged (sector, size, financial projections, etc.), • project feasibility study from the technical, economic and financial points of view, • description of the proposed financial and legal structure, • working programme and detailed budget proposal.
<p><u>FACILITY 2:</u> Operations prior to implementation of the project</p> <ul style="list-style-type: none"> • description of the company or promoter presenting a proposal, including information on their financial situation, • description of the project under consideration, • preliminary financing plan for the investment or development project, • working plan covering the operations to be carried out, • breakdown of the budget for the proposed operation. 	<p><u>FACILITY 4:</u> Project start-up and development</p> <ul style="list-style-type: none"> • description of the company, including its financial position, • description of the technical assistance and training, • working programme; main assistance objectives, • detailed budget proposal.

THE CDI'S ACP ANTENNAE NETWORK

WEST AFRICA REGION

- BENIN**
 • Centre de promotion pour l'emploi et la petite et moyenne entreprises (CEPEPE)
 Tél.: +229 31 44 47 Fax: +229 31 59 50
- BURKINA FASO**
 • Ministère de l'Industrie, du Commerce et des Mines
 Tél.: +226 307305 Fax: +226 307305
- CAPEVERDE**
 • I.A.D.E.
 Tél.: +238 61 44 44 Fax: +238 61 24 34
- CÔTE D'IVOIRE**
 • Chambre de Commerce et de l'Industrie de Côte d'Ivoire
 Tél.: +225 324700 Fax: +225 272117
- GAMBIA**
 • HISA
 Tél.: +220 229 848 Fax: +220 229 024
- GHANA**
 • Ghana Investment Promotion Centre (GIPC)
 Tél.: +233 21 665 125 Fax: +233 21 663 801
- GUINEA**
 • Office de promotion des investissements en Côte d'Ivoire (O.P.I.V.)
 Tél.: +224 444985 Fax: +224 413161
- GUINEA BISSAU**
 • Ministério dos Recursos Naturais e da Indústria
 Tél.: +245 215653 Fax: +245 221050
- LIBERIA**
 • Subah-Bellevue Associates
 Tél.: +231 221519 Fax: +231 226260
- Venture Development Incorporated
 Tél.: +231 225229 Fax: +231 225217
- MALI**
 • Centre d'assistance aux projets, entreprises et sociétés (CAPES)
 Tél.: +223 222259 Fax: +223 228005
- MAURITANIA**
 • Fédération des Industries et des Mines (FIM)
 Tél.: +222 2 595 83 Fax: +222 2 595 83
- Association professionnelle promotion de la pêche artisanale et du crédit maritime musul en Mauritanie
 Tél.: +222 2 451 44 Fax: +222 2 450 46
- NIGER**
 • Ministère de l'Industrie et de l'artisanat
 Tél.: +227 733781 Fax: +227 733781
- Akelen
 Tél.: +227 741021 Fax: +227 741812
- NIGERIA**
 • N.I.O.B. Ltd.
 Tél.: +234 1 663470
- New Nigeria Development Co. Ltd (NNDC)
 Tél.: +234 62 200250 Fax: +234 62 25482
- G. Odeh and Associates
 Tél.: +234 1 822712 Fax: +234 1 2662315
- Miroca Ltd.
 Tél.: +234 1 834 108 Fax: +234 1 261 44 96
- Grid Consulting
 Tél.: +234 1 266 5657 Fax: +234 1 266 7905
- SENEGAL**
 • Sonelgi
 Tél.: +221 25 51 80 Fax: +221 246565SIERRA

- LEONE**
 • Ajax Consultants Ltd.
 Tél.: +232 22 229028 Fax: +232 22 229680
- TOGO**
 • Chambre de Commerce, d'Agriculture & d'Industrie du Togo (CCAI)
 Tél.: +228 212045 Fax: +228 214730

CENTRAL AFRICA REGION

- BURUNDI**
 • B.N.D.E.
 Tél.: +257 227806 Fax: +257 223775
- CAMEROON**
 • BETA Conseil
 Tél.: +237 432585 Fax: +237 431691
- CENTRAL AFRICAN REPUBLIC**
 • C.C.I.M.A.
 Tél.: +236 611668 Fax: +236 613561
- Kode Conseil, s.r.l.
 Tél.: +236 610035 Fax: +236 610035
- CHAD**
 • Q.R.I.T.
 Tél.: +235 515164 Fax: +235 515884
- CONGO**
 • B.D.E.A.C.
 Tél.: +242 830212 Fax: +242 830266
- CODIS Conseil
 Tél.: +242 837135 Fax: +242 836199
- GABON**
 • ASAFCO Gabon, Sarl
 Tél.: +241 724061 Fax: +241 724061
- EQUATORIAL GUINEA**
 • Ministerio de Industria, Comercio y Promoción Empresarial
 Tél.: +240 9 3386 Fax: +240 9 33339
- RWANDA**
 • Ministère de l'Industrie et de l'Artisanat
 Tél.: +250 76715
- SAO TOME E PRINCIPE**
 • Ministerio de Economia e Finanças
 Tél.: +239 12 22747 Fax: +239 12 22182
- ZAIRE**
 • SOFIDE
 Tél.: +243 12 25619

EAST AFRICA REGION

- COMOROS**
 • Banque de développement des Comores
 Tél.: +269 73 08 18
- Centre d'appui au secteur privé (CASP)
 Tél.: +269 73 03 38 Fax: +269 73 03 13
- ERITREA**
 • Asmara Chamber of Commerce
 Tél.: +291 1 121 388 Fax: +291 1 120 138
- ETHIOPIA**
 • H.Asherafi Shiferaw
 Tél.: +251 1 553330 Fax: +251 1 553330
- KENYA**
 • AM Enterprises
 Tél.: +254 2 744955 Fax: +254 2 750194
- MADAGASCAR**
 • Société d'études et de relations pour le développement (SERDI)
 Tél.: +261 2 21335 Fax: +261 2 29669
- Association nationale commission

- de Toedan Indon
 Tél.: +261 2 32183 Fax: +261 2 32184
- MAURITIUS**
 • Chambre de Commerce et d'Industrie de Maurice (CCI)
 Tél.: +230 208 3301 Fax: +230 208 0076
- SEYCHELLES**
 • Seychelles Bank of Seychelles
 Tél.: +248 224471 Fax: +248 224274
- SUDAN**
 • Sudan Development Corporation
 Tél.: +249 11 452151 Fax: +249 11 452148
- TANZANIA**
 • International Services & Supplies Ltd. (ISS)
 Tél.: +255 51 21401 Fax: +255 51 32 895
- Small Industries Development Organisation (SIDO)
 Tél.: +255 51 27691 Fax: +255 51 21011
- Tanzania Development Finance Company Ltd.
 Tél.: +255 51 48 144
- UGANDA**
 • Centre for Trade Promotion Ltd.
 Tél.: +256 41 24 29 62 Fax: +256 41 24 55 97

SOUTHERN AFRICAN REGION

- ANGOLA**
 • Ministerio de Industria
 Tél.: +244 2 33 70 55 Fax: +244 2 39 2400
- BOTSWANA**
 • Economic Consultancy (PTY) Ltd.
 Tél.: +267 31 31 31 Fax: +267 31 20 90
- LESOTHO**
 • Lesotho National Development Corporation (LNDC)
 Tél.: +266 32 20 12 Fax: +266 31 0038
- MALAWI**
 • Investment and Development Bank of Malawi Ltd. (INDEBANK)
 Tél.: +265 62 00 55 Fax: +265 63 5703
- MOZAMBIQUE**
 • Instituto Nacional de Desenvolvimento da Industria Local (INDIL)
 Tél.: +258 1 42 21 79 Fax: +258 1 43 0226
- NAMIBIA**
 • Investors Centre
 Tél.: +264 61 22 99 33 Fax: +264 61 22 0278
- Chamber of Commerce & Industry
 Tél.: +264 22 20 00 Fax: +264 33 690
- SWAZILAND**
 • Swaziland Industrial Development Company
 Tél.: +268 433 91 Fax: +268 45 619
- ZAMBIA**
 • Small Industries Development Organisation (SIDO)
 Tél.: +260 1 22 42 84 Fax: +260 1 22 2568
- ZIMBABWE**
 • Zimbabwe Investments Centre
 Tél.: +263 4 75 79 31 Fax: +263 4 75 7937

CARIBBEAN REGION

- ANTIGUA and BARBUDA**
 • BAHAMAS
 • Bahamas Chamber of Commerce
 Tél.: +1 809 3222145 Fax: +1 809 3224649
- BARBADOS**
 • Barbados Investment and Development Corporation (BIDC)

- Tél.: +1 809 4275350 Fax: +1 809 4267802
- BELIZE**
 • Belize Chamber of Commerce & Industry
 Tél.: +501 2 75108 Fax: +501 2 274984
- DOMINICA (COM)**
 • Insurance Marketing & Promotion Services Ltd.
 Tél.: +1 809 4483372 Fax: +1 809 4485592
- DOMINICAN REPUBLIC**
 • DOMINEX
 Tél.: +1 809 5355540 Fax: +1 809 5333215
- GRENADA**
 • Grenada Industrial Development Corporation (IDC)
 Tél.: +1 809 4441035 Fax: +1 809 4444828
- GUAYANA**
 • The (private) Sector Commission of Guyana Ltd.
 Tél.: +592 2 57170 Fax: +592 2 70725
- JAMAICA**
 • JAMPRO Ltd.
 Tél.: +1 809 9297190 Fax: +1 809 9249650
- ST CHRISTOPHER and NEVIS**
 • Chamber of Commerce and Industry
 Tél.: +1 809 4651980 Fax: +1 809 4654490
- ST LUCIA**
 • St. Lucia National Development Corporation
 Tél.: +1 809 4523074 Fax: +1 809 4521841
- ST VINCENT and GRENADINES**
 • St. Vincent Development Corporation
 Tél.: +1 809 4571358 Fax: +1 809 4572838
- SURINAME**
 • Chamber of Commerce and Industry
 Tél.: +597 4735327 Fax: +597 474779
- TRINIDAD and TOBAGO**
 • Caribbean Business Services Ltd.
 Tél.: +1 809 633 2103 Fax: +1 809 633 2103

PACIFIC REGION

- FJI**
 • Fiji Trade and Investment Board
 Tél.: +679 31 59 88 Fax: +679 30 1780
- KIRIBATI**
 • Ministry of Natural Resources Development
 Tél.: +686 21091 Fax: +686 21120
- PAPUA NEW GUINEA**
 • Department of Trade and Industry Central Government Offices
 Tél.: +675 27 11 15 Fax: +675 25 2401
- SOLOMON ISLANDS**
 • Ministry of Commerce & Primary Industry
 Tél.: +677 262 30 Fax: +677 250 84
- TONGA**
 • Tonga Development Bank
 Tél.: +676 213 33 Fax: +676 22 755
- TUVALU**
 • Development Bank of Tuvalu
 Tél.: +688 20 850 Fax: +688 20 850
- WESTERN SAMOA**
 • Development Bank of Western Samoa
 Tél.: +685 228 61 Fax: +685 23 888
- YANUATU**
 • Ministry of Economic Affairs
 Tél.: +678 22770 Fax: +678 25640

THE CDI'S EUROPEAN INSTITUTIONAL NETWORK

- AUSTRIA**
 • Wirtschaftskammer Österreich
 Österreichische Organisation
 Tél.: +43 1 50105 4403 Fax: +43 1 50206 255
- BELGIUM**
 • Administration générale de la coopération au développement - AGCD
 Tél.: +32 2 519 02 11 Fax: +32 2 500 65 85
- Ministère de la Région Wallonne - DARE
 Tél.: +32 2 211 55 11 Fax: +32 2 211 55 37
- Ministère de la Région Bruxelles-Capitale
 Tél.: +32 2 513 97 00 Fax: +32 2 511 52 55
- DENMARK**
 • The Industrialization Fund for Developing Countries - IFU
 Tél.: +45 33 14 25 75 Fax: +45 33 32 25 24
- FINLAND**
 • Finfund
 Tél.: +358 0 348 434 Fax: +358 0 348 433 46
- Ministry of Foreign Affairs, Department for Development Cooperation
 Tél.: +358 0 104 151 Fax: +358 0 134 162 09
- FRANCE**
 • Assemblée des chambres françaises de commerce et d'industrie - ACFCI
 Tél.: +33 1 40 69 37 00 Fax: +33 1 47 20 61 28

- Association régionale pour le développement et la coopération industrielle internationale - ADECI
 Tél.: +33 91 14 43 28 Fax: +33 91 81 85 37
- INTERCO Aquitaine - Agence de coopération internationale
 Tél.: +33 56 51 20 92 Fax: +33 56 48 28 19
- Institut régional de développement - IRCOD
 Tél.: +33 26 70 31 31 Fax: +33 26 64 10 95
- Caisse française de développement - CFD
 Tél.: +33 1 40 06 31 31 Fax: +33 1 47 42 75 14
- ERAI - Entreprise Rhône Alpes International
 Tél.: +33 78 34 83 48 Fax: +33 78 34 59 85
- GERMANY**
 • Deutsche Investitions und Entwicklungsgesellschaft - D.I.E.G.
 Tél.: +49 221 498 63 81 Fax: +49 221 498 61 11
- GREECE**
 • Organization for the Development of Small and Medium Sized Industries and Handicrafts - EOMMEK
 Tél.: +30 1 77 00 654 Fax: +30 1 77 78 694
- IRELAND**
 • Irish Trade Board - ITB
 Tél.: +353 1 269 50 11 Fax: +353 1 269 50 20

- ITALY**
 • Ente Regionale per lo Sviluppo Economico del Territorio - ERVET
 Tél.: +39 51 23 05 67 Fax: +39 51 22 33 52
- Istituto Nazionale per il Commercio Estero - ICE
 Tél.: +39 6 59 921 Fax: +39 6 59 926 899
- GRAND-DUCHY OF LUXEMBOURG**
 • Ministère des Affaires étrangères
 • Direction des Relations Économiques Internationales et de la Coopération
 Tél.: +352 478 23 62 Fax: +352 22 20 48
- Lux-Development s.a.r.l.
 Tél.: +352 43 39 68 Fax: +352 43 38 08
- PORTUGAL**
 • Banco de Fomento e Exterior - BFE
 Tél.: +351 1 356 10 71 Fax: +351 1 352 27 58
- Banco Português de Atlântico - BPA
 Tél.: +351 1 346 33 52 Fax: +351 1 342 32 94
- Fundo Para a Cooperação Económica - FCE
 Tél.: +351 1 352 06 07 Fax: +351 1 315 85 43
- Investimentos, Comércio e Turismo de Portugal - ICEP
 Tél.: +351 1 793 01 03 Fax: +351 1 794 08 26
- SPAIN**

- COPCA
 Tél.: +34 3 48 49 605 Fax: +34 3 48 49 666
- Instituto Español de Comercio Exterior - ICEX
 Tél.: +34 1 349 61 00 Fax: +34 1 431 61 28
- Sociedad para la Promoción y Reconstrucción Industrial - SPRU
 Tél.: +34 4 47 97 000 Fax: +34 4 47 97 023
- Instituto de Fomento de Andalucía - IFA
 Tél.: +34 5 490 00 18 Fax: +34 5 490 63 00
- Promociones Exteriores de Canarias - PROEXCA
 Tél.: +34 28 41 14 34 Fax: +34 28 41 43 04
- SWEDEN**
 • Swedish International Development Cooperation Agency, Business and Enterprise Development Division - SIDA
 Tél.: +46 8 698509 Fax: +46 8 249290
- Svedfund International - AB
 Tél.: +46 8 7259400 Fax: +46 8 203093
- UNITED KINGDOM**
 • Commonwealth Development Corporation - CDC
 Tél.: +44 171 828 44 86 Fax: +44 171 828 65 05
- Department of Trade and Industry - DTI
 Tél.: +44 171 215 57 50 Fax: +44 171 215 57 12

These lists of the CDI's ACP and European Union networks, published in November 1995, are regularly updated. If you would like to receive the most recent lists, together with the names and references of the people to contact, please send your request to:

CDI
 Avenue Herrmann Debroux 52, B-1160 Brussels, Belgium
 Tel.: +32 2 679 18 11 - Fax: +32 2 675 26 03
 November 1995

CRATerre-EAG - International Centre for Earth Construction - School of Architecture of Grenoble

CRATerre-EAG is an international scientific and technical organisation based in Grenoble, France. In the course of over 20 years of activity in some fifty countries, CRATerre-EAG has built up a body of skills and knowledge covering all aspects of earth construction at all levels. The present offer of services is specific and relates only to compressed earth block (CEB) technology.

Standardisation

With its considerable experience of CEB standardisation, as well as with earth construction in general, CRATerre-EAG can provide services relating to standardisation covering a very wide spectrum: updating standards, drafting standards on new subject areas, standards on new building systems, standards for specific products, standards on production equipment, standards on calculation methods, drawing up national standards, auditing enterprises, information seminars, training laboratories in testing, training in a quality-based approach, writing teaching documents to be distributed amongst users (explanatory and illustrated versions), translation, documentary research, setting up certification systems, etc.

Training

CRATerre-EAG can provide training of various kinds at the request of clients. Training may relate to areas as wide-ranging as: identifying types of earth, equipment operation and maintenance, CEB production, implementation, quality control, etc. Training sessions are preferably held at CRATerre-EAG's premises where all suitable and necessary teaching resources are permanently available. Training sessions in the field can also be envisaged.

Technical assistance

Clients can call on CRATerre-EAG's skills in all areas relating to CEB promotion, production and construction; e.g. identification missions, geotechnical surveys, feasibility studies, identification tests, equipment installation, production organisation, introducing the quality-based approach, drafting specifications and norms, laboratory testing, brickwork management, market surveys, commercial strategy, elaborating building systems, architectural design, structural calculations, economic studies, recommendations on building systems, evaluation, etc.

Procurement

Clients may request CRATerre-EAG to carry out all tasks relating to the purchase of production equipment, materials and laboratory equipment, such as: short-listing equipment, contacts with manufacturers, negotiations on purchase price, purchase, monitoring equipment manufacture and delivery times, taking delivery of equipment and materials, arranging transport.

Dissemination

In collaboration with client technical works can be published relating to the installation, the use and the maintenance of equipment, plans for the construction of buildings, reports on tests, standards etc.

Research

Clients may request research to be conducted in precise areas, the results of which will be used by the clients, e.g. work on particular stabilisers, developing processes for recycling industrial waste, designing specific building systems, etc.

It is stressed that CRATerre-EAG's services are not solely restricted to CEBs, but that clients may also call upon CRATerre-EAG to extend its services to other earthen products. All services must be covered by a contract.

CRATerre-EAG is a network partner of basin (Building Advisory Service and Information Network), a coalition of experts with worldwide experience in all aspects of the building sector.

basin network partners are actually:

- **Argentina:** CEVE (Centro Experimental de la Vivienda Economica);
- **France:** CRATerre-EAG (International Centre for Earth Construction);
- **Germany:** GATE/GTZ (German Appropriate Technology Exchange Deutsche Gesellschaft für Technische Zusammenarbeit);
- **India:** Development Alternatives;
- **Kenya:** Shelter Forum;
- **Switzerland:** SKAT (Swiss Centre for Development Cooperation in Technology and Management);
- **United Kingdom:** ITDG (Intermediate Technology Development Group).

basin's experience and expertise include:

- assessing local resources, skills and opportunities,
- developing enabling and people-focussed policy approaches,
- reviewing standards and regulations,
- investment appraisal for profitable local production,
- training programmes for technology awareness and construction,
- information dissemination,
- research and development programmes,
- strengthening local capacities for the promotion of a vibrant building industry,
- project management.

CRATerre-EAG/basin

International Centre for Earth Construction
School of Architecture of Grenoble
B.P. 53
F - 38092 VILLEFONTAINE CEDEX
FRANCE
Telephone +33 4 74 95 43 91
Telefax +33 4 74 95 64 21
Email craterre-eag.villefontaine@grenoble.archi.fr

ARSO - African Regional Organization for Standardization

Establishment

The African Regional Organization for Standardization (ARSO) is an African intergovernmental organisation established in January 1977 by the United Nations Economic Commission for Africa (UNECA) and the Organisation of African Unity (OAU).

Membership

Membership of ARSO is open to member states of the United Nations Economic Commission for Africa and the Organisation of African Unity. By 1996 ARSO's member states numbered 24.

Structure and administration

The general assembly, consisting of the member States of the organisation, is the supreme organ of ARSO. At its sessions, held every three years, the general assembly devotes its attention to general policy matters and priority programmes, and considers and approves future proposals.

The council consists of the President, the Vice-president, the Treasurer and nine elected members of the organisation. It guides, subject to the directions of the general assembly, the activities of the organisation. The council also directs the implementation of resolutions, approves annual programmes of work and budget and reviews achievements made thereof.

The Secretariat, headed by the Secretary General, services the general assembly, meetings of the council and the subsidiary organs of the organisation. The Secretariat, subject to the general directions of the council, is entrusted with the administration of the organisation and carries out resolutions and implements work programmes and priorities.

Objectives

In executing its mandates as spelt out by the Lagos plan of action, ARSO has put in place various organs, tools and programmes. The Lagos plan of action was further reinforced by the Abuja treaty of 1991, establishing the African Economic Community and the associated protocol on standardisation, quality assurance and measurement systems.

The objectives of ARSO are :

- to promote standardisation activities in Africa;
- to elaborate regional standards;
- to promote social, industrial and economic development and provide consumer protection and human safety by advocating and establishing activities concerning standardisation in Africa;
- to promote the harmonisation of the views of its members and their contribution and participation at the international level in the field of standardisation.

Technical work

The technical work of ARSO is concerned with the operation of activities in the following principal fields :

- preparation and issuance of Africa Regional Standards;
- quality control activities;
- certification marking operations;

- metrology;
- laboratory testing;
- technical information and consultancy services in standardisation ;
- training programmes; and
- international liaison and participation.

The technical work of the organisation is carried out in accordance with the provisions detailed out in the "Rules Governing Technical Activities of ARSO".

Activities and services

It is planned for the activities under the following programme elements to be carried out:

- preparation and issuance of African Regional Standards;
- operation of regional network of documentation and Information systems (ARSO-DISNET);
- operation of a regional network of testing, metrology and instrumentation centers (ARSO-TIMICNET), aimed at developing and promoting the sharing of testing, metrology and instrumentation services;
- operation of regional certification systems (ARSO-CERT) which is a continent-wide third party certification system for products of conformity to African Regional Standards or other technically equivalent standards;
- operation of the ARSO accreditation scheme (ARAS), the system to accredit certification, test and inspection bodies after assessing their independence, integrity and technical competence in their areas of operation;
- conducting training programmes in the field of standardisation, quality control, certification and metrology;
- assisting member states in the development of their national mechanisms for standardisation, quality control, certification and metrology;
- co-ordinating the views and participation of member states in international standardisation activities; and
- undertaking promotional activities.

Expected impact

The conduct of ARSO activities is expected to make the following impacts towards the realisation of the plan objectives stipulated in the Lagos plan of action for the economic development of Africa:

- facilitating the development and expansion of intra-Africa trade;
- contributing towards the realisation objectives of the African region;
- assisting in strengthening of the national standards and measurement capabilities of member states and promoting the effective application of science and technology for the socio-economic development of member states and that of the region ;
- assisting in the integration and co-ordination of transport and communication infrastructures in the region;
- contributing towards the rapid integration of the various economic sectors of the African region as stipulated in the final act of Lagos plan of action; and
- providing a forum for the effective co-ordination of the views and participation of African countries in international standardisation work.

ARSO

African Regional Organization for Standardization
 12 th Floor - City Hall Annex - Muindi Mbingu Street, Nairobi
 P.O Box 57363, Nairobi, Kenya
 Telephone +254 2 330 895, 330 882
 Telefax +254 2 218 792
 Email arso@arso.gn.apc.org, or, arso@arso.sasa.unon.org

REGIONAL STANDARDISATION PROCEEDINGS

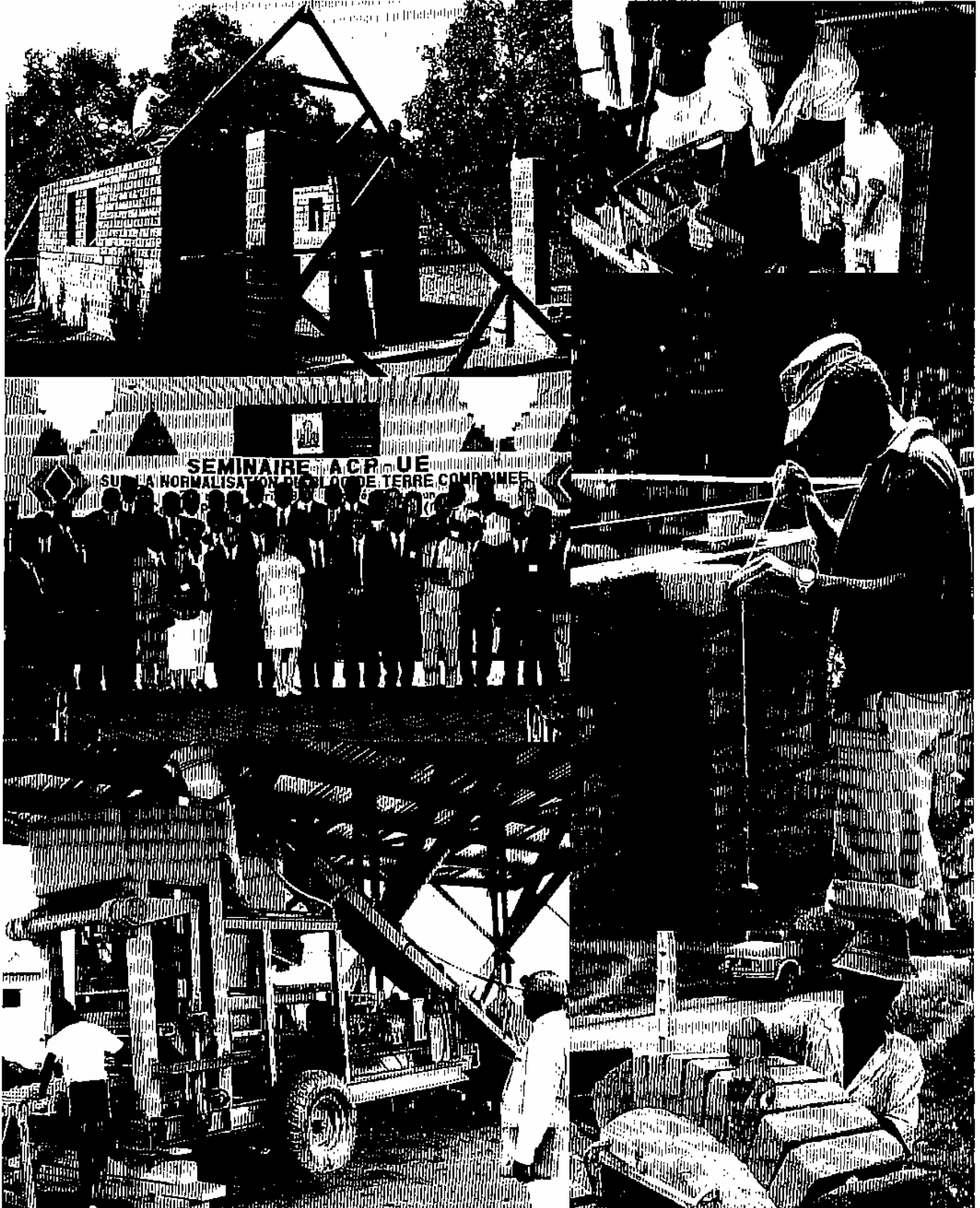

Draft normative texts on compressed earth blocks were prepared as a result of the work of the members of the International Scientific and Technical Committee "Compressed earth block technology".

Once ready, these documents were presented to ARSO (African Regional Organization for Standardization) which decided to attribute to them a provisional standards numbering system.

The normative texts were then submitted to an assembly of 37 experts from 16 countries who attended the ACP-EU seminar on the standardisation of compressed earth blocks which was held by the CDI from 23 to 27 April 1996 in Yaoundé, Cameroon. These experts, representing the whole of the building industry, studied and revised the provisional standards texts on compressed earth blocks, as well as standardisation procedures in the course of four working sessions in plenary assembly and three working sessions in technical sub-committees.

121 pages of text relating to 10 standards were examined. Over 100 amendments were incorporated and a series of new standards was drawn up.

During the final plenary session, the amended texts were presented by the chairmen of the technical sub-committees and submitted for agreement to all the experts present. The latter suggested a few additional amendments, which were incorporated, following which the texts received their overall agreement, and consensus was obtained.

These amended provisional texts were then submitted to all of the members of the International Scientific and Technical Committee, which suggested a number of corrections and clarifications, respecting the spirit of the Yaoundé seminar.

ARSO submitted those texts to a formal vote by all the national standards bodies of its 24 member states. Their comments and corrections were incorporated into the texts. Under the auspices of the Technical Committee on Building and Civil Engineering (ARSO/TC3) and after having satisfied ARSO's procedures for the approval, the standards were approved and on 18 October 1996, ARSO conferred on them the numbering system and the status of African Regional Standards.

Experts of the International Scientific and Technical Committee «Compressed earth block technology»

This committee drew up the content of the provisional standards texts and revised the provisional standards adopted by the experts attending the Yaounde seminar.

- **Algeria** : Benouali A., Centre National d'Etudes et de Recherches Intégrées du Bâtiment.
- **Australia** : Heathcote K., Sydney University of Technology.
- **Australia** : Hornibrook J., Queensland University of Technology.
- **Australia** : Walker P., University of New England.
- **Cameroon** : Bidjocka C., Ecole Nationale Supérieure Polytechnique.
- **France** : El Gharbi Z., National Engineering Institute for Public Works.
- **France** : Fadli A., CEAA-Terre - School of Architecture of Grenoble.
- **France** : Houben H., International Centre for Earth Construction - School of Architecture of Grenoble, Coordinator of the Committee.
- **France** : Mesbah A., National Engineering Institute for Public Works.
- **France** : Olivier M., National Engineering Institute for Public Works. Secretary General of the Committee.
- **France** : Simonnet J., (ex) Centre Expérimental de recherches et d'études du Bâtiment et des Travaux Publics.
- **India** : Maïni S., Auroville Building Center.
- **South Africa** : Morris J., University of the Witwatersrand.
- **South Africa** : Wallis B.L., Council for Scientific and Industrial Research.
- **Togo** : Samah O., Centre de la Construction et du Logement.
- **United Kingdom** : Webb D., (ex) Building Research Establishment.

Experts of the Yaounde Seminar on the standardisation of compressed earth blocks

These experts adopted by consensus the provisional standards texts during the plenary assembly of 26 April 1996.

- **Burkina Faso:** Yamba T., Ministry of Infrastructure, Housing and Urban Planning.
- **Burundi:** Baransaka D., Société Immobilière Publique.
- **Burundi:** Hamenyimana E., Bureau d'Etudes Topographiques, Urbanisme et Construction.
- **Burundi:** Nzinahora G., Bureau Burundais de Normalisation et Contrôle de la Qualité.
- **Cameroon:** Bidjocka C., Ecole Nationale Supérieure Polytechnique.
- **Cameroon:** Chendjouo F., Ministère de l'Urbanisme et de l'Habitat.
- **Cameroon:** Diwouta Kotto D., Cabinet d'architecture Diwouta.
- **Cameroon:** Djoda H., Crédit Foncier Cameroun.
- **Cameroon:** Epée R., Ecole Nationale Supérieure Polytechnique.
- **Cameroon:** Kuete Sonkoue M., Terkocam.
- **Cameroon:** Otye Elemva G., Société Immobilière du Cameroun.
- **Cameroon:** Sendé J.V., Arter.
- **Cameroon:** Tanke Toka J.Th., Ecofac.
- **Central African Republic:** Feiganazou A., Société Dominor.
- **Central African Republic:** Wodobode P., Ministry of Public Works, Housing and Land Use.
- **Central African Republic:** Zouta-Yamandja G., Chambre de Commerce d'Industrie des Mines et de l'Artisanat.
- **Chad:** Schärer R., Arc en Terre.
- **Congo:** Birangui Mbys P., Sobaco.
- **Congo:** Moudzingoula J., Ministry of Industrial Development Energy and Mining.
- **Congo:** Moukakou B., High Commission to Urban planning, housing and registry.
- **Cote d'Ivoire:** Aka J.J., Côte d'Ivoire Normalisation.
- **Cote d'Ivoire:** Romagnolo Ph., Art'Terre.
- **Equatorial Guinea:** Cayetano Toerida E.M., Consultec.

- **Equatorial Guinea:** Ela Kung Nkono G., Ministry of Industry and Small/Medium Enterprise Promotion.
- **France:** Houben H., International Centre for Earth Construction - School of Architecture of Grenoble.
- **France:** Olivier M., National Engineering Institute for Public Works.
- **France:** Simmonet J., Centre Expérimental de recherches et d'études du Bâtiment et des Travaux Publics.
- **Gabon:** Béluriée P., Université des Sciences et Techniques de Masuku.
- **Gabon:** Ndegue F., Crédit Foncier du Gabon.
- **Gabon:** Ngoua-Obiang P., Ministry of Public Works and Construction.
- **Germany:** Strassburger H., Deutsche Gesellschaft für Technische Zusammenarbeit.
- **Nigeria:** Ogunsusi V., Centre for Earth Construction Technology.
- **Sao Tome and Principe:** Bonfim F., Ministère de l'Industrie.
- **Senegal:** Sarr B., Institut Sénégalais de Normalisation et Organisation Régionale Africaine de Normalisation.
- **Togo:** Kouliho A., Société de Contrôle Technique.
- **Togo:** Samah O., Centre de la Construction et du Logement.
- **United Kingdom:** Lowe L., Intermediate Technology Development Group and Building Advisory Service and Information Network.

National standards bodies of the member states of ARSO

These organisations took part in the formal vote resulting in ARSO conferring the status of African Regional Standards on 18 October 1996.

- **Burkina Faso** : Direction Générale de la Qualité et de la Métrologie.
- **Cameroon** : Ministry of Commerce and Industry.
- **Cote d'Ivoire** : Côte d'Ivoire Normalisation.
- **Egypt** : Egyptian Organization for Standardization and Quality Control.
- **Ethiopia** : Ethiopian Authority for Standardization.
- **Ghana** : Ghana Standards Board.
- **Guinea** : Institut de Normalisation et de Métrologie.
- **Guinea Bissau** : Ministry of Natural Resources and Industry.
- **Kenya** : Kenya Bureau of Standards.
- **Liberia** : Bureau of Standards.
- **Libya** : National Centre of Standardization and Metrology.
- **Malawi** : Malawi Bureau of Standards.
- **Mauritius** : Mauritius Standards Bureau.
- **Niger** : Ministry of Mining, Energy, Industry and Crafts.
- **Nigeria** : Standards Organization of Nigeria.
- **Senegal** : Institut Sénégalais de Normalisation.
- **Sierra Leone** : Bureau of Standards.
- **Sudan** : Standards and Quality Control Department.
- **Tanzania** : Tanzania Bureau of Standards.
- **Togo** : Ministry of Industry and State Companies.
- **Tunisia** : Institut National de Normalisation et de Propriété Industrielle.
- **Uganda** : Uganda National Bureau of Standards.
- **Zaire** : Département de l'Economie Nationale et de l'Industrie.
- **Zambia** : Zambia Bureau of Standards.

The industrial production of compressed earth blocks enables the transformation of earth into resistant, durable and inexpensive elements of masonry without firing.

The production and utilisation of compressed earth blocks creates employment, generates foreign currency savings and requires relatively low investments which are within the reach of small and medium-sized enterprises.

Thanks to their technical and economic performance, compressed earth blocks are now increasingly in demand in ACP countries as building material both for private housing and for public buildings such as dispensaries, hospitals, schools, covered markets, crafts centres, administrative premises.

For offers received from designers and from construction companies to be valid, they need to respect local legislation.

This guide puts forward a body of standards ratified as the African Regional Standards which should henceforth enable planners to accept proposals from contractors and builders for the utilisation of compressed earth blocks.

The guide is also a tool for the drawing up of national standards as regards the use of compressed earth blocks.

OTHER TITLES

"Technologies series"

- 1 — Briquetting of vegetal residues
- 2 — Valorisation of phosphate in Africa
- 3 — Soap production
- 4 — Paint production
- 5 — Compressed earth blocks: production equipment
- 6 — Flexible polyurethane foam : discontinuous process
- 7 — The intensive poultry industry in the Sahelian zone
- 8 — Sand and aggregates : production equipment
- 9 — Small bakeries and the valorisation of local cereals in ACP countries
- 10 — Packaging of fruit juices and non carbonated fruit drinks
- 11 — Compressed earth blocks : Standards
- 12 — Technical guide for Tilapia Farming

"Contracts and partnerships series"

- 1 — Purchasing industrial equipment
- 2 — Setting up in ACP countries
- 3 — ACP-EU : A guide to partnerships in industry

"Project evaluation and financing series"

- 1 — Financial resources for industrial projects in ACP countries
- 2 — FINAN Manual
- 3 — Facilities and instruments for industrial cooperation

"Export development series"

- 1 — Exporting sea products

"Forum series"

- 1 — The agri-food sector in Western Africa, 1995
- 2 — Construction and building materials in Central Africa, 1995

"CDI Dossiers series"

- 1 — Lake fishing in Uganda : the Nile perch
- 2 — Commercial perspectives for rose farms in East and Southern Africa
- 3 — Developing the fishing sector in Mozambique
- 4 — Export opportunities for processed fruit from the Caribbean